

C-ADP-118 AND C-ADP-119 PEDESTAL MOUNT INSTALLATION INSTRUCTIONS

1. ASSEMBLE THE PEDESTAL MOUNT SHELF TO THE PEDESTAL MOUNT BASE USING THE SUPPLIED HARDWARE (GSM31999 AND GSM30016-1) ACCORDING TO THE EXPLODED VIEW TO THE RIGHT.
2. PLACE THE PEDESTAL MOUNT ASSEMBLY ONTO THE MOUNTING PLATFORM, ALIGNING THE PEDESTAL MOUNT BASE MOUNTING HOLES WITH THE HOLES IN THE MOUNTING PLATFORM. CONSOLE TOP AND HDM POLE MOUNTING OF C-MD-119 IS SHOWN BELOW. THE PEDESTAL MOUNT AND MOTION DEVICE CAN MOUNT TO ANY FLAT SURFACE USING A 2.125" SQUARE MOUNTING PATTERN.
3. USING THE 1/4-20 HARDWARE PROVIDED WITH THE MOTION DEVICE, INSERT BOLTS THROUGH THE MOUNTING PLATFORM AND PEDESTAL MOUNT BASE INTO THE THREADED HOLES OF THE MD COG WHEEL BASE.
4. ATTACH THE DESIRED DISPLAY MOTION DEVICE TO THE PEDESTAL MOUNT SHELF USING THE HARDWARE SUPPLIED WITH THE DISPLAY MOTION DEVICE.
5. WITH THE DISPLAY MOUNTED, ADJUST THE HEIGHT OF THE PEDESTAL MOUNT SHELF TO THE DESIRED VIEWING POSITION BY LOOSENING THE THREE 1/4-20 NYLOCK NUTS ON THE BACK OF THE PEDESTAL MOUNT ASSEMBLY. ONCE DESIRED HEIGHT IS ACHIEVED, RETIGHTEN THE HARDWARE TO COMPLETE THE INSTALLATION.

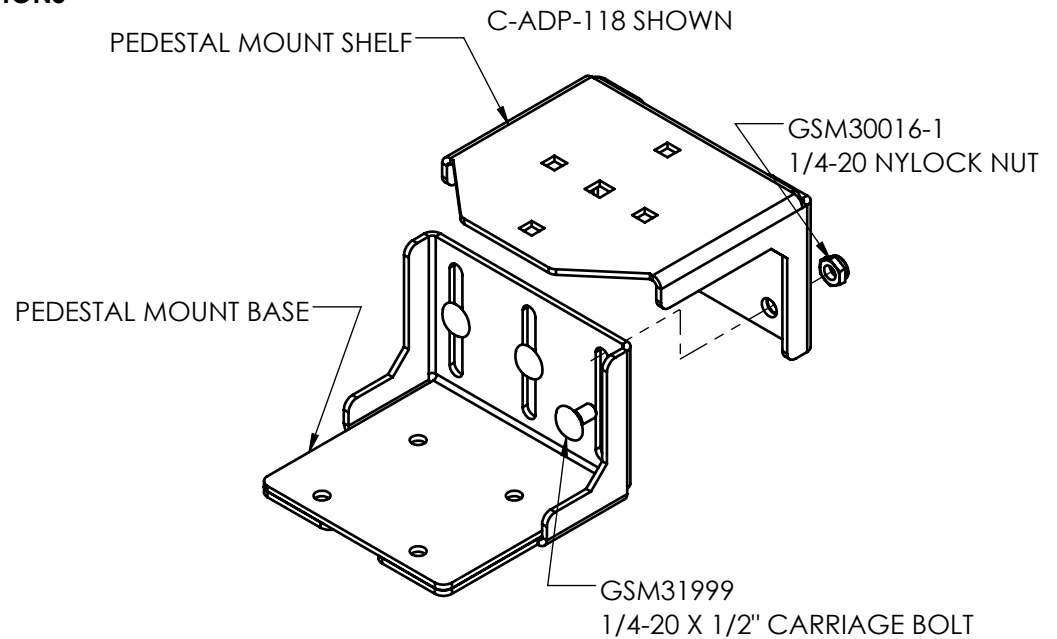

C-ADP-119 SHOWN

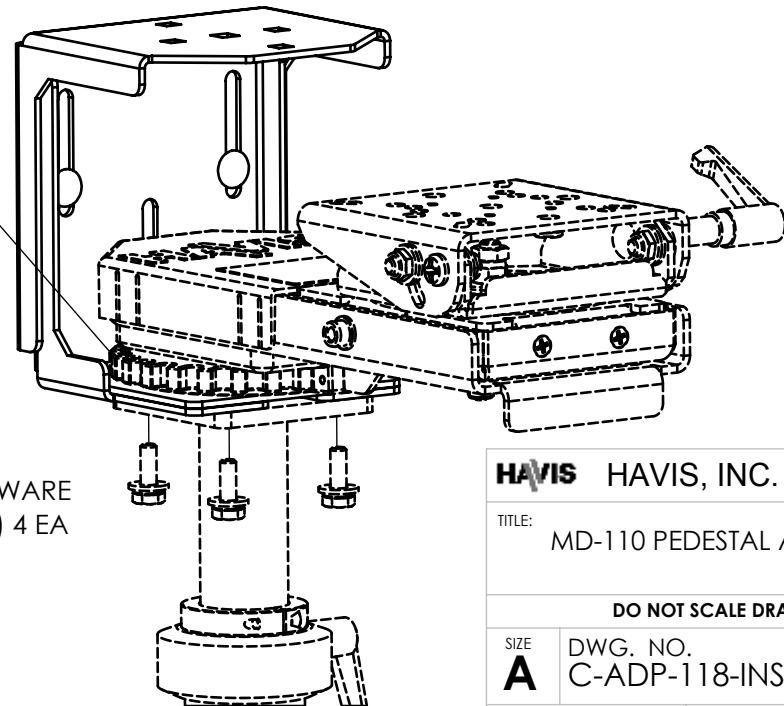

C-ADP-118 SHOWN

MD COG WHEEL BASE

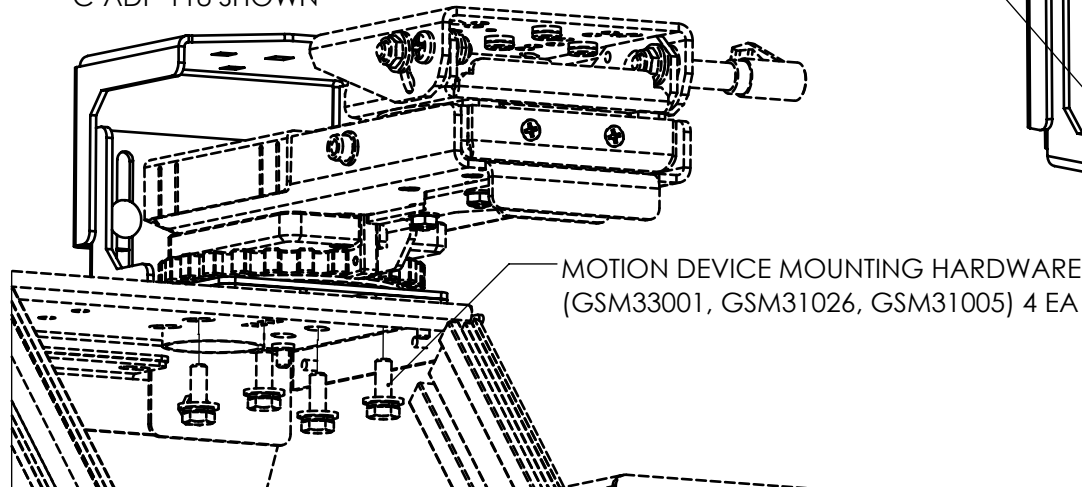

MOTION DEVICE MOUNTING HARDWARE
(GSM33001, GSM31026, GSM31005) 4 EA

HAVIS HAVIS, INC. 75 JACKSONVILLE RD.
WARMINSTER, PA. 18974
1-800-524-9900

TITLE: MD-110 PEDESTAL ADAPTER

DO NOT SCALE DRAWING

SIZE A	DWG. NO. C-ADP-118-INST	REV 3-17
WEIGHT (LB): 2.53	SCALE: 1:3	SHEET 1 OF 1