

## **ASSEMBLY:**

1. ATTACH THE REAR BRACKET TO THE FACE PLATE USING THE TWO INCLUDED #10-32 KEPS NUTS
2. SLIDE THE RADIO INTO THE BRACKET, MAKING SURE THAT THE CURVED PORTION AT THE BOTTOM OF THE FACE OF THE RADIO ALIGNS WITH THE CURVED PORTION OF THE OPENING IN THE FACE PLATE.
3. SECURE THE RADIO TO THE BRACKET USING THE HARDWARE INCLUDED WITH THE RADIO.
4. MOUNT THE ASSEMBLED BRACKET AND RADIO INTO THE CONSOLE USING THE FOUR INCLUDED TORX SCREWS.

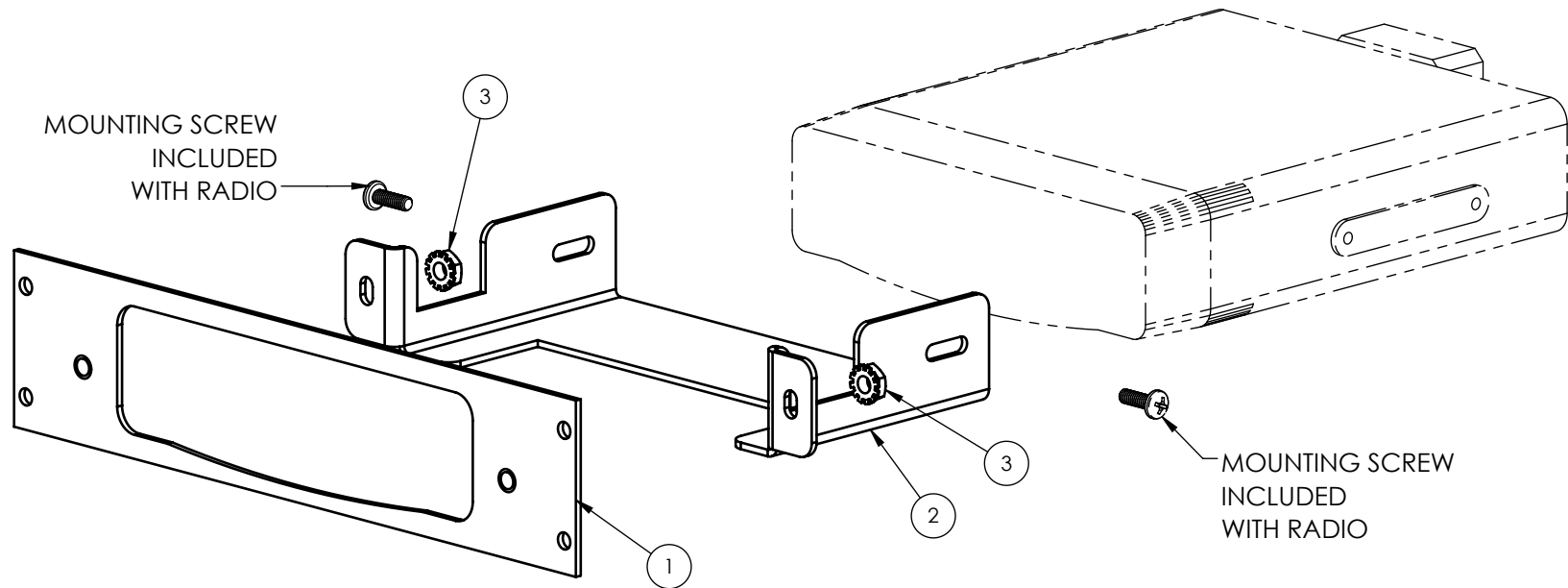

ITEM NO.	QTY.	PART NUMBER	DESCRIPTION
1	1	10-007819	BRKT, EB, 2.0 YAESU 8900/8800
2	1	10-007820	BRKT, YAESU 8900/8800 EB
3	2	GSM30028	NUT 10-32 KEPS ZP, BLK
4	1	C-HK-5	HARDWARES. TORX, EB AND FILLER PLATES (NOT SHOWN)
5	1	C-EB20-YFT-INST	ASSEMBLY, C-EB20-YFT EQUIPMENT BRACKET

<b>HAVIS HAVIS, INC.</b>		<small>75 JACKSONVILLE RD. WARMINSTER, PA. 18974 1-800-524-9900</small>	
TITLE: ASSEMBLY, C-EB20-YFT EQUIPMENT BRACKET			
<b>DO NOT SCALE DRAWING</b>			
SIZE <b>A</b>	DWG. NO. C-EB20-YFT-INST	REV 3-16	
WEIGHT (LB): 2.62		SCALE: 1:2	SHEET 1 OF 1