

INSTALLATION:

1. ROUTE STRAP THROUGH LOWER HOOK, BASE AND INTO THE RATCHET AS SHOWN
2. PLACE BASE ONTO PALLET TRUCK HEAD AND POSITION THE HOOK UNDER THE CROSSBAR. PULL STRAP TO REMOVE SLACK.
3. POSITION U-BOLT UNDER PALLET TRUCK SWIVEL HEAD AND INSERT THROUGH BASE AND PLACE 2 SPACERS ONTO FREE ENDS OF U BOLT. USE SQUARE OR ROUND U-BOLT FOR THE BEST FIT.
4. PLACE POLE MOUNT ON TOP OF BASE WITH REAR SLOTS OVER U-BOLT ENDS AND SECURE WITH 2 EACH OF 3/8" FLAT WASHERS, LOCK WASHERS AND NUTS.
5. INSTALL 2 EACH OF THE 5/16 X 1" LONG BOLTS, WASHERS AND LOCK WASHERS THROUGH THE POLE BASE PLATE AND INTO THE THREADED HOLES IN THE BASE.
6. TIGHTEN HARDWARE, MAKING SURE POLE IS VERTICAL AND CENTERED ON PALLET TRUCK
7. SLIDE SUPPORT TABS DOWN UNTIL THEY SECURELY SUPPORT THE SIDES OF THE BASE.
8. IF DESIRED, 1/4-20 BOLTS AND NUTS (INCLUDED) MAY BE INSTALLED INTO SUPPORT TABS FOR FURTHER SUPPORT.
9. TIGHTEN STRAP UNTIL POLE IS SECURE ON PALLET TRUCK.
10. FREE END OF STRAP MAY BE CUT OFF AND THE END HEATED TO PREVENT FRAYING, OR THE FREE LENGTH MAY BE TUCKED INSIDE THE BASE.
11. ATTACH THE ADAPTOR PLATE TO THE TOP OF THE POLE USING 4 OF THE 5/16" FLAT WASHERS AND NUTS.

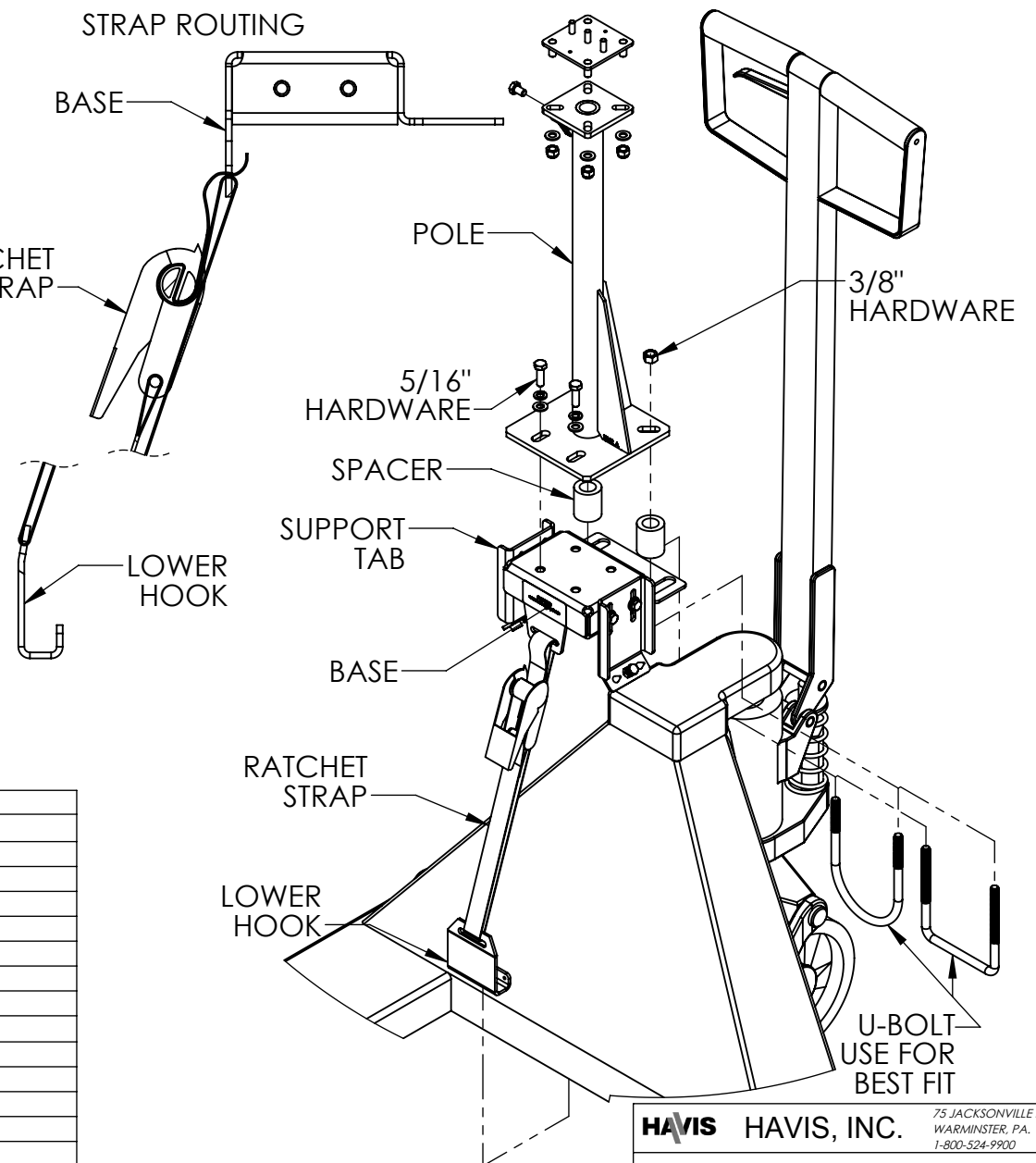

ITEM NO.	QTY.	PART NUMBER	DESCRIPTION
1	2	10-004011	SPACER, 1.5"
2	1	10-007462	BRKT, LOWER HOOK, PALLET JACK MOUNT
3	1	10-007463	BRKT, POLE MOUNT, PALLET JACK
4	2	10-007586	TAB, SUPPORT, PALLET JACK MOUNT
5	1	30-007560	ASSEMBLY, POLE MT, PALLET JACK
6	4	CM93084	RUBBER BUMPER
7	1	GSM20098	HRDW,U-BOLT,3/8-16,3-5/8"ld,3-3/8"h,ZINC
8	1	GSM20099	RPL,RATCHET,STRAP,1"x10",ENDLSS,LOOP
9	1	GSM20405	SQUARE U-BOLT, 3/8-16, 4"ID X 5"LG
10	2	GSM30005	NUT 1/4-20 HEX BLK, ZINC, GRD 5
11	4	GSM31005	WASHER, 1/4 FLAT ZP, BLACK
12	6	GSM31006	WASHER, 5/16" FLAT, SAE ZP
13	2	GSM31007	WASHER 3/8 FLAT ZP
14	4	GSM31026	WASHER 1/4 LOCK ZP BLK
15	2	GSM31027	WASHER, 5/16" LOCK, ZP
16	2	GSM31088	WASHER 3/8 LOCK, ZNC, BLK
17	4	GSM33001	SCREW 1/4-20 x 3/4" HHCS ZP BLK
18	2	GSM33002	SCREW 1/4-20 X 1 HHCS ZP
19	2	GSM33012	SCREW 5/16-18 X 1 HHCS ZP
20	1	10-002592	HDM ADAPTOR PLATE
21	4	GSM30017	NUT 5/16-18 NYLOCK ZP, BLK
22	1	GSM33010	SCREW 5/16-18 X 1/2 HHCS ZP

HAVIS HAVIS, INC. 75 JACKSONVILLE RD.
WARMINSTER, PA. 18974
1-800-524-9900

TITLE: INSTALLATION, PALLET TRUCK MOUNT

DO NOT SCALE DRAWING

SIZE A	DWG. NO. C-MH-2001-INST	REV 4-16
------------------	----------------------------	-------------

WEIGHT (LB): 148.41 SCALE: 1:8 SHEET 1 OF 1