

REV.	DESCRIPTION
9-14	UPDATED VIEW
10-14	UPDATED VIEW
03-15	UPDATED VIEW
11-18	UPDATED COMPONENTS
1-19	10-009431-12 REPLACED 10-002432-12

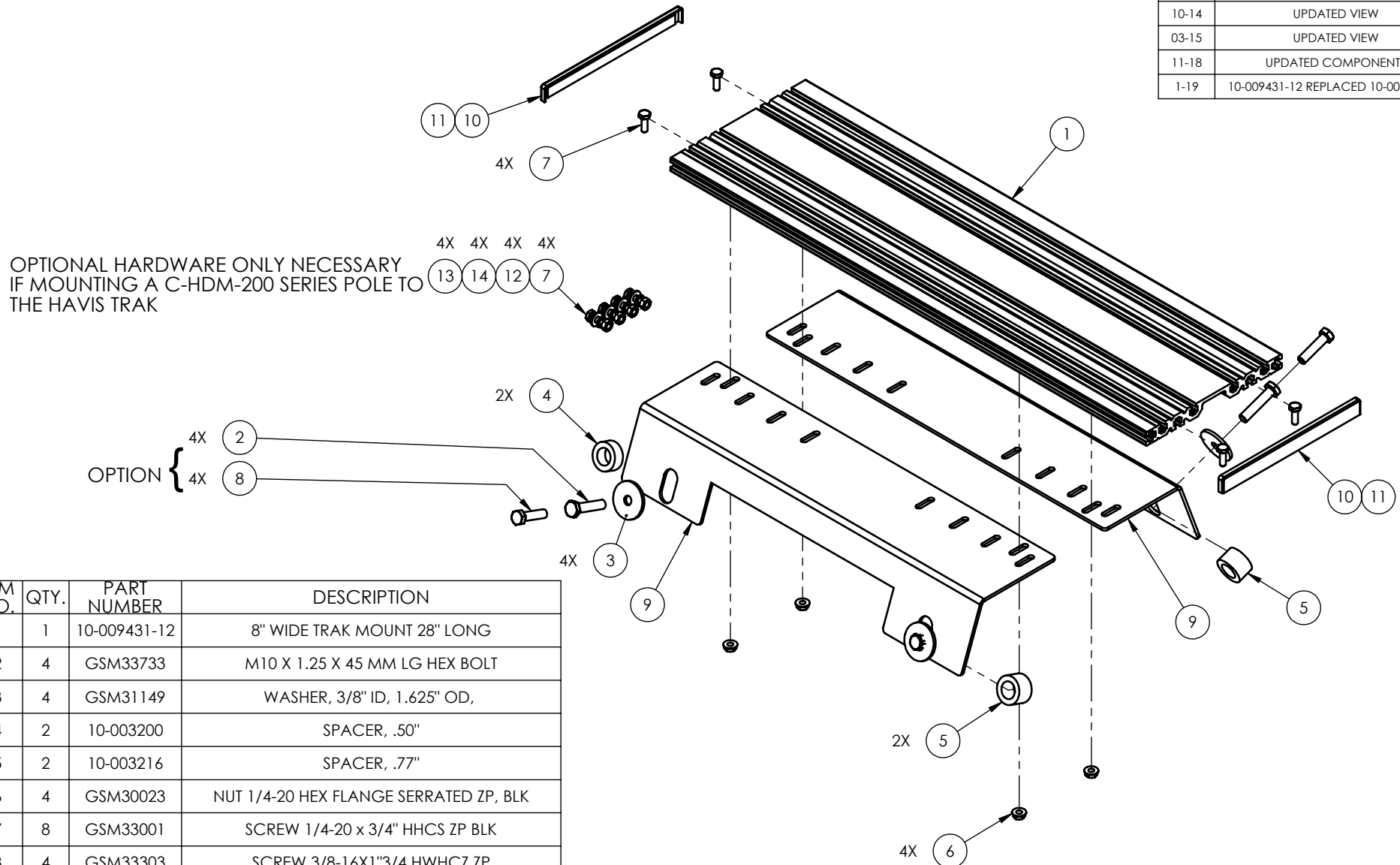

ITEM NO.	QTY.	PART NUMBER	DESCRIPTION
1	1	10-009431-12	8" WIDE TRAK MOUNT 28" LONG
2	4	GSM33733	M10 X 1.25 X 45 MM LG HEX BOLT
3	4	GSM31149	WASHER, 3/8" ID, 1.625" OD,
4	2	10-003200	SPACER, .50"
5	2	10-003216	SPACER, .77"
6	4	GSM30023	NUT 1/4-20 HEX FLANGE SERRATED ZP, BLK
7	8	GSM33001	SCREW 1/4-20 x 3/4" HHCS ZP BLK
8	4	GSM33303	SCREW 3/8-16X1"3/4 HWHCZ ZP
9	2	10-006193	BRKT, TRAK MOUNT, '14 SILVERADO 1500/'15 TAHOE
10	2	30-002527A	8" EXTRUSION END CAP, TRAK MOUNT
11	2	10-002851	GASKET, END TRIM (TMW) WIDE
12	4	GSM31005	WASHER, 1/4 FLAT ZP, BLACK
13	4	GSM30005	NUT 1/4-20 HEX BLK, ZINC, GRD 5
14	4	GSM31026	WASHER 1/4 LOCK ZP BLK

HAVIS HAVIS, INC. 75 JACKSONVILLE RD.
WARMINSTER, PA. 18974
1-800-524-9900

TITLE: INSTALLATION, TRACK MOUNT, 2014 SILVERADO 1500/ 2015 TAHOE

DO NOT SCALE DRAWING

SIZE A	DWG. NO. C-TMW-GMC-03-INST	REV 1-19
------------------	-------------------------------	-------------

WEIGHT (LB): 18.57 SCALE: 1:4 SHEET 1 OF 2

INSTALLATION INSTRUCTIONS

**NOTE THESE INSTRUCTIONS ASSUME THE CUSTOMER IS MOUNTING A HAVIS TRAK.
IF A HAVIS TRAK IS NOT BEING USED ONLY POINTS 1, 4, 5 AND 11 ARE RELEVANT.**

1. REMOVE CENTER SEAT IF EQUIPPED BY REMOVING THE 4 BOLTS SECURING IT TO THE VEHICLE FLOOR.
2. TURN TRACK UPSIDE DOWN AND SLIDE FOUR (4) 1/4-20 X 3/4" BOLTS INTO SLOTS.
3. PLACE BRACKETS OVER THE BOLTS IN THE TRACK AND LOOSELY SECURE WITH 4 SERRATED NUTS.
4. POSITION ASSEMBLED TRACK AND BRACKETS OVER THE SEAT MOUNTING HOLES IN THE FLOOR OF THE VEHICLE.

NOTE: IN VEHICLES NOT FACTORY EQUIPPED WITH A CENTER CONSOLE OR SEAT, THE MOUNTING HOLES IN THE FLOOR OF THE VEHICLE MAY NOT BE THREADED. IN THIS CASE, USE THE SELF-TAPPING 3/8 X 1-3/4" LONG HEX HEAD BOLTS INSTEAD OF THE M10 X 35MM BOLTS FOR INSTALLATION.

5. PLACE SPACERS BETWEEN THE FLOOR OF THE VEHICLE AND THE TRACK MOUNTING BRACKETS. THE SPACERS ARE TWO SIZES, 1/2" AND 3/4".
THE 3/4" THICK SPACERS ARE LOCATED TOWARDS THE FRONT OF THE VEHICLE.
6. SNUG THE 4 MOUNTING BOLTS DOWN, BUT DO NOT TIGHTEN.
7. POSITION THE TRACK AS DESIRED, AND MARK ITS LOCATION ON THE BRACKETS.
8. REMOVE THE TRACK AND BRACKETS FROM THE VEHICLE.
9. ALIGN THE TRACK WITH THE MARKS AND TIGHTEN THE 1/4-20 FLANGED NUTS.
10. INSTALL THE TRACK AND BRACKETS BACK INTO THE VEHICLE, MAKING SURE THE 3/4" SPACERS ARE ON THE FRONT 2 BOLTS AND TIGHTEN ALL 4 BOLTS.
11. ATTACH END CAPS WITH SUPPLIED DOUBLE SIDED ADHESIVE AFTER CONSOLE HARDWARE INSTALLATION IS COMPLETE.

HAVIS HAVIS, INC.		75 JACKSONVILLE RD. WARMINSTER, PA. 18974 1-800-524-9900
TITLE: INSTALLATION, TRACK MOUNT, 2014 SILVERADO 1500/ 2015 TAHOE		
DO NOT SCALE DRAWING		
SIZE A	DWG. NO. C-TMW-GMC-03-INST	REV 1-19
WEIGHT (LB):	SCALE: 1:4	SHEET 2 OF 2