

**INSTALLATION:**

1. ATTACH "U" SHAPE FRONT BRACKET TO THE FLOOR / TRANS HUMP USING TWO (2) M6 X 20MM HEX BOLTS AND 1/4" FLAT WASHERS. THE MOUNTING HOLES WILL LINE UP WITH OEM THREADED HOLES IN THE FLOOR.
2. LOOSELY ATTACH 1/4" X 1/2" HEX BOLTS AND HEX NUTS IN EACH SIDE HOLE OF FRONT BRACKET. (TWO EACH SIDE)
3. LOOSELY ATTACH REAR BRACKETS TO REAR SIDE OF TUNNEL PLATE SLOTS WITH TWO (2) 1/4" X 1/2" HEX BOLTS AND HEX NUTS. ONE EACH SIDE WITH BENDS GOING INWARD UNDER PLATE.
4. SLIDE TUNNEL PLATE ASSEMBLY FORWARD ONTO BOLTS /NUTS ON FRONT BRACKET.
5. REMOVE BACKING FROM ADHESIVE STRIP AND INSTALL END CAP TO FRONT END OF TRACK.
6. ATTACH REAR BRACKETS TO THE OEM REAR FLOOR FLANGES WITH M6 X 20MM HEX BOLTS AND 1/4" FLAT WASHERS.
7. POSITION TUNNEL PLATE JUST BEHIND LOWER PLASTIC INSTRUMENT PANEL AND TIGHTEN HARDWARE.
8. IF YOUR VEHICLE HAS THE OPTIONAL OEM REAR WIRE CONDUIT, ATTACH THE REAR COVER / ADAPTOR TO THE END OF THE TUNNEL PLATE WITH 1/4" X 1/2" HEX BOLTS AND HEX NUTS. ATTACH THE LOWER PART OF THE REAR COVER TO THE OEM CONDUIT WITH M6 X 20MM HEX BOLTS AND 1/4" FLAT WASHERS.
9. IF NOT USING THE REAR CONDUIT COVER/ ADAPTER, ATTACH THE REMAINING END CAP TO THE REAR OF THE TRACK.

**NOTE:** ADDITIONAL 1/4" HARDWARE PROVIDED TO ATTACH C-HDM-200 SERIES POLES TO C-TMW SERIES. INSERT INTO TRAK CHANNEL BEFORE INSTALLING END CAPS.

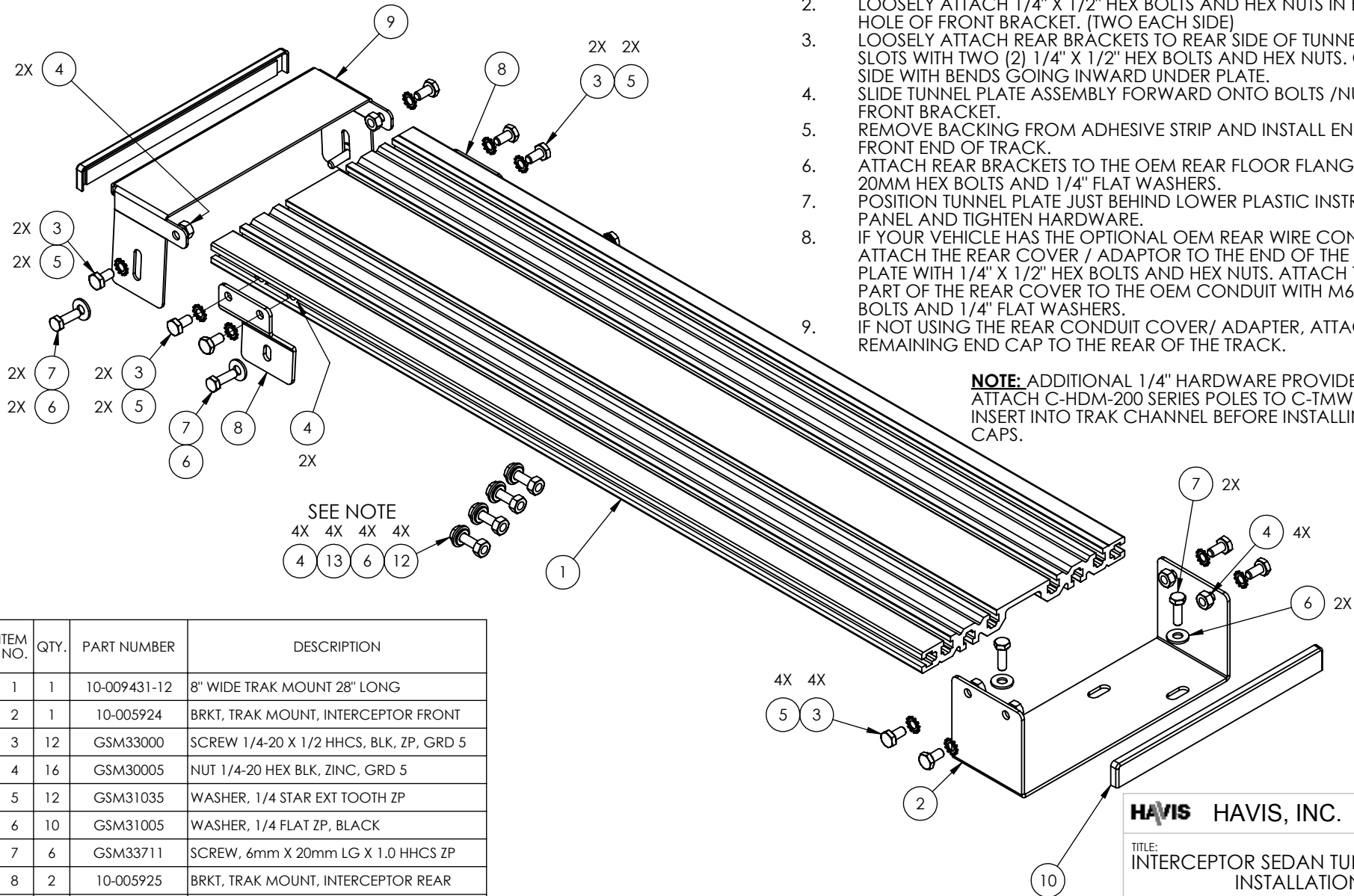

SEE NOTE  
4X 4X 4X 4X  
4 13 6 12

ITEM NO.	QTY.	PART NUMBER	DESCRIPTION
1	1	10-009431-12	8" WIDE TRAK MOUNT 28" LONG
2	1	10-005924	BRKT, TRAK MOUNT, INTERCEPTOR FRONT
3	12	GSM33000	SCREW 1/4-20 X 1/2 HHCS, BLK, ZP, GRD 5
4	16	GSM30005	NUT 1/4-20 HEX BLK, ZINC, GRD 5
5	12	GSM31035	WASHER, 1/4 STAR EXT TOOTH ZP
6	10	GSM31005	WASHER, 1/4 FLAT ZP, BLACK
7	6	GSM33711	SCREW, 6mm X 20mm LG X 1.0 HHCS ZP
8	2	10-005925	BRKT, TRAK MOUNT, INTERCEPTOR REAR
9	1	10-005926	BRKT, TRAK MOUNT INSE CONDUIT COVER
10	2	30-002527A	8" EXTRUSION END CAP, TRAK MOUNT
12	4	GSM33001	SCREW 1/4-20 x 3/4" HHCS ZP BLK
13	4	GSM31026	WASHER 1/4 LOCK ZP BLK

**HAVIS HAVIS, INC.** 75 JACKSONVILLE RD.  
WARMINSTER, PA. 18974  
1-800-524-9900

TITLE:  
INTERCEPTOR SEDAN TUNNEL TRACK  
INSTALLATION

**DO NOT SCALE DRAWING**

SIZE <b>A</b>	DWG. NO. C-TMW-INSE-01_INST	REV 1-19
------------------	--------------------------------	-------------

WEIGHT (LB): 23.86      SCALE: 1:4      SHEET 1 OF 1