

# INSTALL INSTRUCTIONS C-VS-0812-INUT-1

## 2013-2019 FORD INTERCEPTOR UTILITY with STANDARD INTERIOR Vehicle Specific Console

**Note:** *This console can be used in an Interceptor Utility with Interior Upgrade (Code 65U). However the optional CM007650 side trim panel kit must be ordered.*

*OEM inner dash bracket shown in step 8 is different (recessed further back)*

*The installer will also have to slightly modify the upper support bracket and supply two (2) ¼" x 3 ½" bolts and two (2) 3" spacers for mounting upper bracket. (multiple hex nuts can be used to create spacers)*

*See last photo for reference*

**CM007650 trim panels will also work with the standard Interceptor Utility without OEM console.**

**TOOLS REQUIRED:**

Phillips Screw Driver	Standard Socket Set	T-20 Torx Bit
Metric Socket Set	Wire Cutters	Wire Crimping Tool

**INSTALLATION PARTS AND MOUNTING HARDWARE:**

<u>QTY</u>	<u>DESCRIPTION</u>	<u>PART#</u>
1	Main Console housing	
1	Lower rear mounting bracket	CM004941
1	Upper rear mounting bracket	CM004942
1	Upper front support bracket	CM007429
1	Driver side mounting bracket	CM007477
1	Passenger side mounting bracket	CM007425
1	Backing plate	CM007478
1	Adaptor plate for OEM aux panel	CM005898
1	Adaptor bracket for OEM optional conduit	CM007945
2	Velcro set 1" x 1"	GSM20080
8	1/4" Serrated nut	GSM30023
4	10-32 keps nut	GSM30028
4	1/4" Flat washer	GSM31005
2	1/4" Lock washer	GSM31026
1	O-ring for aux panel	GSM31335
8	1/4"x 3/4" Bolt	GSM32000
2	1/4"x 3/4" Sheet metal screw	GSM33001
4	10-32 x 1/2" Machine screw	GSM33072
4	#8-18 x 1/4" Screw	GSM33178
2	6mm x 20mm Machine bolt	GSM33711

**Always!**

- Read all instructions before installing any Havis, Inc. products.
- **Check for obstructions (Wires, brake lines, fuel tank, etc.) before drilling any holes!**
  - Use hardware provided with install kit

C-VS-0812-INUT-1  
Assembly

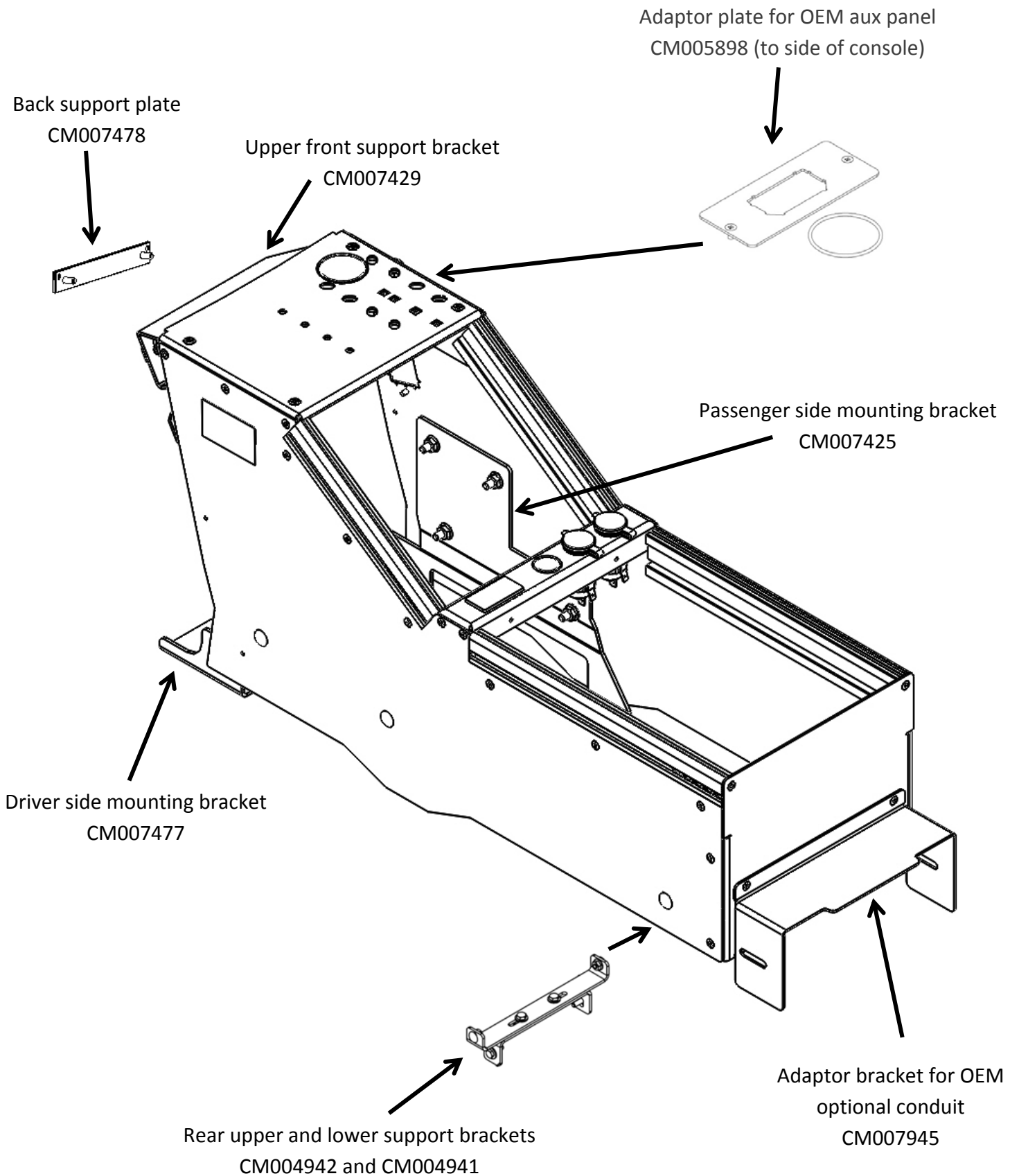



View of center console included with OEM Interior upgrade 65U.

**Optional side panels required for this console CM007650**



Remove OEM tunnel plate and lower dash trim included with Standard Interceptor Utility or center console included with Optional Interior upgrade.

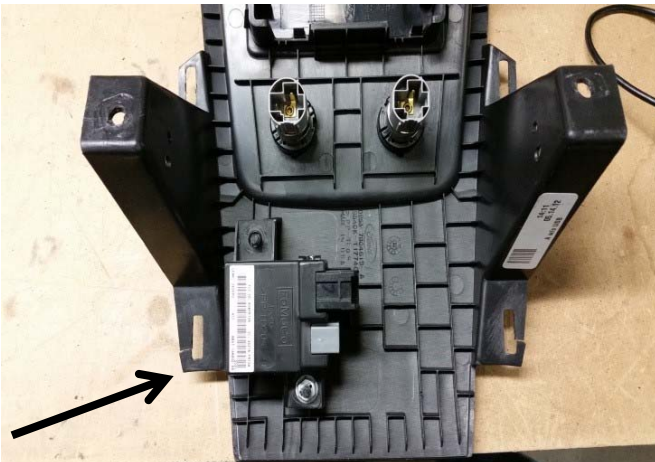

Remove the TPMS module from the lower dash trim.  
**(Module may not be present on 2016+ models)**



Install TPMS module onto vent with supplied Velcro.

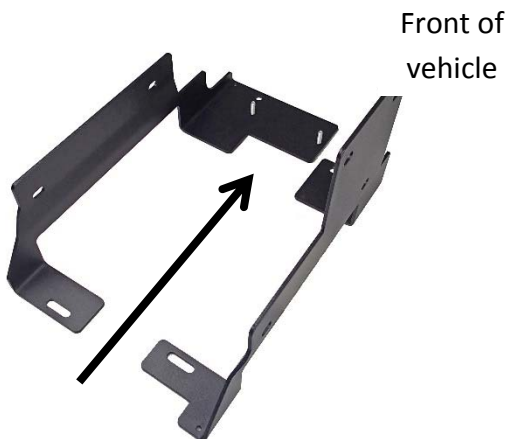

Driver and Passenger floor mounting brackets



Bolt driver and passenger side front hump brackets to floor with previously removed OEM floor bolts.



Attach restraint control module to driver mounting bracket using 10-32 keps nuts.

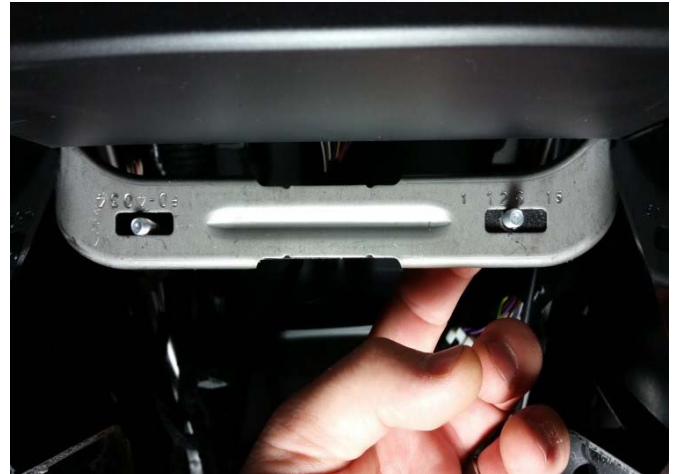

Place backing plate with studs behind the OEM upper center metal dash bracket with the studs facing towards rear of vehicle. **This OEM bracket is different for Interior Upgrade (Code 65U)**  
**See last photo for reference**



Attach console upper front support bracket to backing plate studs with 10-32 nuts

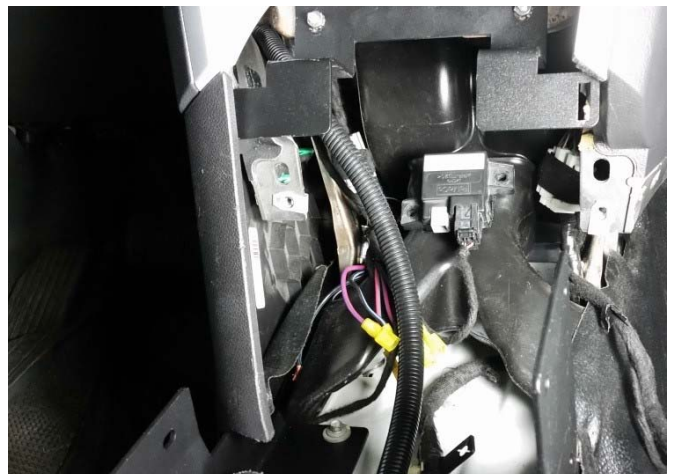

Re-install previously removed OEM trim panels. Attach upper clip into the upper front support bracket as shown.



Attach rear lower bracket to existing OEM mounting flanges with supplied 6mm x 20mm hex bolts and flat washers.



Slide console onto upper front support bracket from rear towards dash. **The bracket must be above the side screws for proper alignment.** Be careful not to scratch dash trim bezels



Loosely attach console top to support bracket with four (4) 10-32 x 3/4" machine screws.



Attach rear upper mounting bracket using and 1/4" x 3/4" bolts and washers. Install 1/4" x 3/4" carriage bolts through the side of the console and attach with 1/4" nuts.

**Tighten all hardware**



Install the OEM aux panel or cover plate to side of console.

**Console shown with optional side fillers**



Wire and install equipment. Photo shows CF-31 with DS-PAN-111, C-MD-112, C-VS-0812-INUT-1, C-AP-0325, C-ARM-107, C-CUP2-I and C-USB-1.

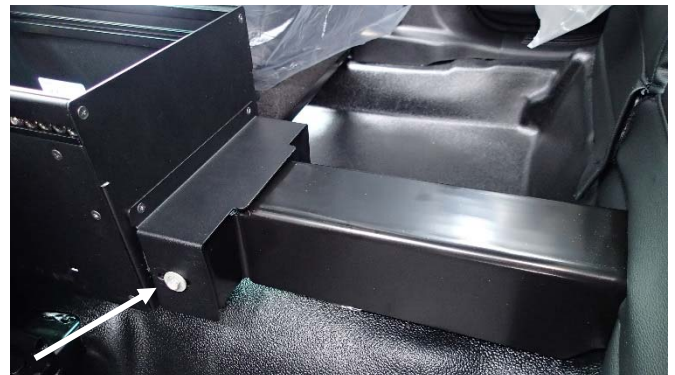

OEM optional wire conduit shown.

Remove console end cutout and attach conduit to adaptor bracket with OEM bolts.

**Note:** Conduit may need to be temporarily removed in order to properly mount console housing.



Example of Interior Upgrade (Code 65U) inner dash bracket with two (2) 1/4" x 3 1/2" bolts and spacers for adapting to upper front support bracket CM007429. Bracket requires two small side trim mount tabs to be cut off. Spacer hardware and bracket modification to be provided by installer.

C-VS-0812-INUT-1\_INST\_8-16