

**INSTALL INSTRUCTIONS C-VS-1800-CHGR-PM**  
**2011-2020 Dodge Charger Police Pursuit Vehicle**  
**Vehicle Specific Console**  
**18" inches of Equipment mounting space with mount for**  
**Brother Pocket Jet Printer**

**TOOLS REQUIRED:**

Phillips Screw Driver                      Metric Socket set                      Standard Socket set                      T-20 Torx Bit

**INSTALLATION PARTS AND MOUNTING HARDWARE:**

<b><u>QTY</u></b>	<b><u>DESCRIPTION</u></b>	<b><u>PART#</u></b>
1	Driver side trim panel	CM008183
1	Passenger side trim panel	CM009216
1	Front printer trim panel	CM008185
1	Printer paper roll rod	CM008118
2	1/4" x 3/4" Lag screw with washer	GSM33060-1
8	#8-18 x 1/4" Flat head screw	GSM33178
1	Startech USB 90° extension cable	GSM70141
4	Aluminum spacer 5/8"	GSM34602
4	1/4" x 1.25" Hex head bolt	GSM33003
4	1/4" Flat washer	GSM31005

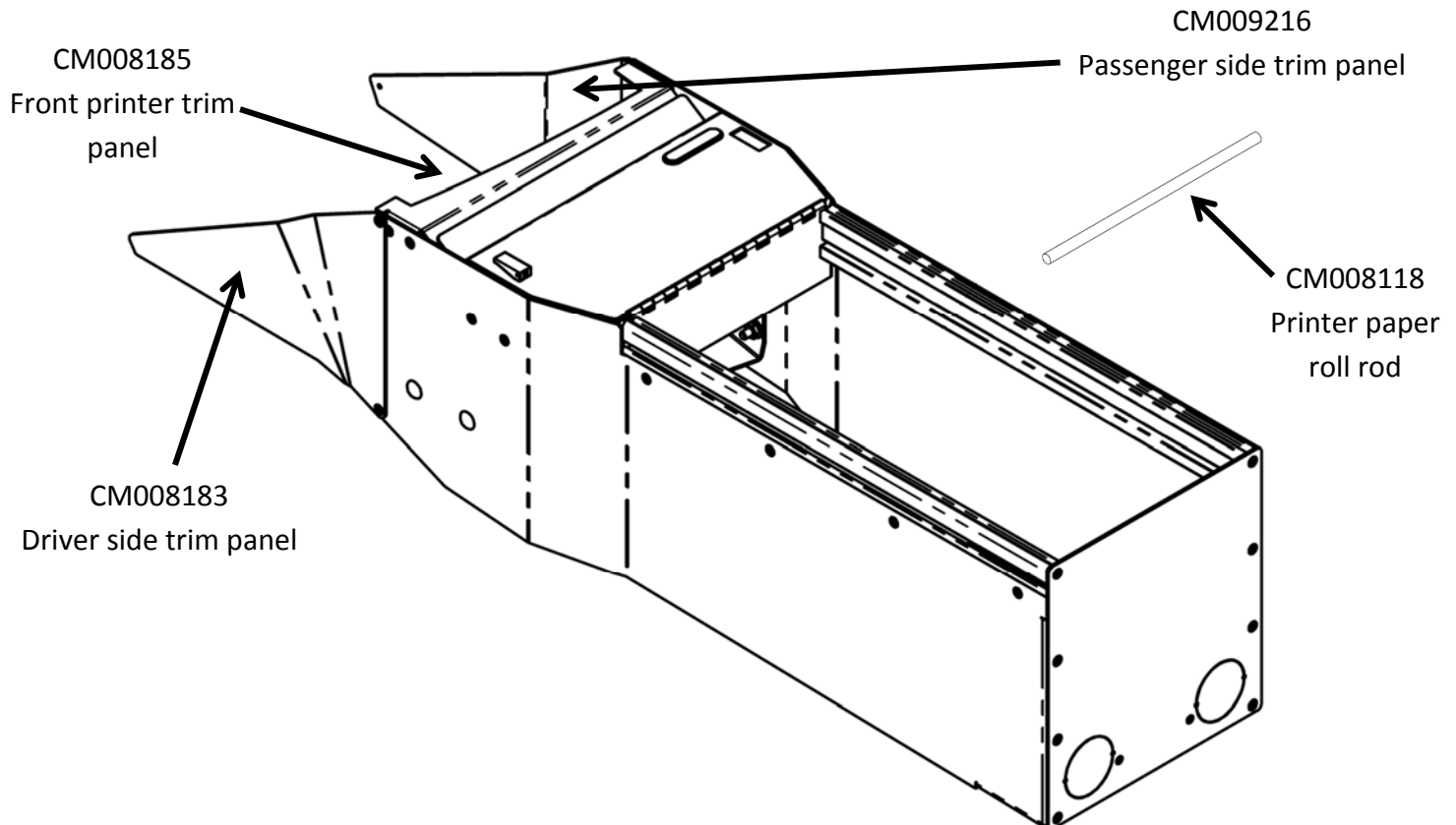

**Always!**

- Read all instructions before installing any Havis, Inc. products.
- **Check for obstructions (Wires, brake lines, fuel tank, etc.) before drilling any holes!**
- Use hardware provided with install kit



Remove forward O.E.M console plastic cover and remove two (2) nuts from front floor bracket. Nuts to be reused later. (10mm)



Remove bolts that hold underside of extrusion to rear floor bracket. (7/16 wrench) Remove rear floor bracket bolts and center console bolt. (10mm)



Remove O.E.M. plastic center console



Remove OEM lighter plugs and AUX panel from factory center console.



Plug O.E.M. wire harness back onto original connectors.



Place console housing into vehicle.



Slide console up to the dash leaving space for the next step.



Attach the front printer trim panel (CM008185) using four (4) #8-18 x 1/4" flat head screws. (GSM33178)



With the front printer trim panel installed place the console tight to the dash. It is easiest to pick up the rear of the console and slide it towards the dash and then lowering the rear.



Install OEM AUX panel and 12V outlets into the side of the console. Plug into factory harnesses.



Make sure the ignition key sense module is moved out of the way and line up the U bracket to the OEM studs.



Place the ignition key sense module on the OEM studs and reinstall previously removed nuts.



Use 1/4 x 3/4 self-threading screws (included in hardware kit) to loosely attach rear of console to existing floor inserts. Inserts located under rubber mat as shown. (7/16 socket)



Attach driver side trim panel on with # 8 x 1/4 Flat head screws. (included with hardware kit)

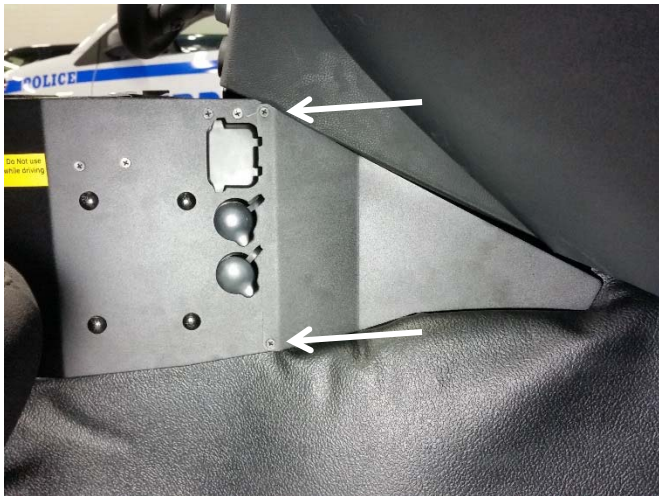

Attach passenger side trim panel on with # 8 x 1/4 Flat head screws. (included with hardware kit)



Pull USB and power cable connections through openings at the left of the printer mount bracket. Plug them into their respective locations and install printer into the mount.



Install plastic rod (CM008426) through the paper spool and place into the console. Feed paper into the printer.



Close lid and confirm final operation, fit, and finish.



For side mount pole applications, spacers and longer hardware for mounting may be required.



5/8" aluminum spacers, 1/4" x 1.25" Hex head bolts and 1/4" washers provided if needed for printer lid clearance.



To open the printer lid, rotate the motion device out of the way.



Install control heads and accessories.



Installation is now complete.



View of DS-PAN-702, C-MD-112, ADP-110, C-UMM-101, KBM-201, KB-101, C-AP-0325, and C-CUP2-I  
C-VS-1800-CHGR-PM\_INST\_2-18