

K9-F23-PT INSTALLATION INSTRUCTIONS

K9 Kit for 2015-2023 Ford F-150 and F-150 SSV Crew Cab Pickup 2017-2023 Ford F-250, 350 and 450 Crew Cab Pickup

TOOLS Needed:

Phillips Screw Driver	Trim panel removal tool	Caulk Gun	Metric Socket set
Standard Socket set	Wire Cutters /Crimpers	Drill & Drill bits	T-20 Torx bit

PARTS & HARDWARE:

<u>QTY</u>	<u>DESCRIPTION</u>	<u>PART #</u>	
		<u>White (or no color)</u>	<u>Black</u>
1	Front bulkhead	24533	25902
1	Driver "B" pillar bracket		18664
1	Passenger "B" pillar bracket		18663
1	21' DS inner "B" pillar bracket		24720
1	21' PS inner "B" pillar bracket		24725
1	21' DS outer "B" pillar bracket		24721
1	21' PS outer "B" pillar bracket		24726
1	Rear bulkhead	24536	25905
1	Rear bulkhead support bracket		18677
1	Dividing wall	24535	25904
1	Emergency egress hatch	18929	18930
1	Emergency egress hatch lower support	18936	18937
1	Lexan cover	24546	
1	C pillar rear window barrier support		24540
1	Rear window access cover		25913
1	Rear window barrier	24541	25908
1	Passenger front bulkhead	24542	25909
1	Floor	24534	25903
1	Front floor support bracket		25911
1	Rear floor support bracket		25912
1	Ceiling	24537	25906
1	Passenger side upper filler	24543	25910
1	Driver side upper filler	18669	23491
1	Passenger side middle filler	24538	25907
1	Driver side middle filler (upper)	18671	23493
1	Driver side middle filler (lower)	18667	23489
1	Lower floor side trim with gas shock cutout		23488
1	Gas shock hole cover plate		23495
2	Under seat vent adaptor base		18673
2	Under seat vent adaptor top		18675
1	Rubber Mat		25897
1	Passenger side door panel	14619	24243
1	Driver side door panel	14605	24242
1	Passenger side hinged window guard		21239
1	Driver side hinged window guard		21238
1	Dome Light Kit (K9-A-106)	17987	
1	Rear wall storage cover	22952	23500
2	Round Vent	25567	
6 feet	2.5" diameter vent hose	20039	
1	Silicone caulk (sealant)	20011	20012
4	1" spacer for floor support bracket	11441	

PARTS & HARDWARE cont.:

QTY	DESCRIPTION	PART #	
1	Installation Hardware Kit	25900	(includes the following)
2	#10 x 1/2" Phillips flat head sheet metal screw	16413	
4	10-32 x 1/2" Phillips flat head machine screw	16584	
2	15" Wire tie	15816	
4	10-32 Nylock nut	16098	
4	3" Hose clamp	15821	
4	#8 x 3/8" T-20 Torx Sheet meatal screw	13405	
16	#8-18 X 1/4" Phillips flat head screw	16425	
69	1/4" x 3/4" Phillips pan head machine screw (SS)	16618	
69	1/4" Flat washer (SS)	16154	
25	1/4" x 3/4" Carriage bolt (SS)	16235	
25	1/4-20 serrated flange nut (silver)	16086	
2	10-32 Keps nut	16017	
2	10-32 x 1/2" Machine screw	16399	
10	#10 x 1/2 Phillips flat head sheet metal screw - SS	16641	
28	#10 x 1/2 Phillips pan head sheet metal screw – SS	16655	
2	Knob	16865	
2	#10 Star washer	16147	
6	#10 x 1/2" Sheet metal screw	16445	
6	#8-18 Pan head screw	25597	
6	Adhesive backed pad	18891	

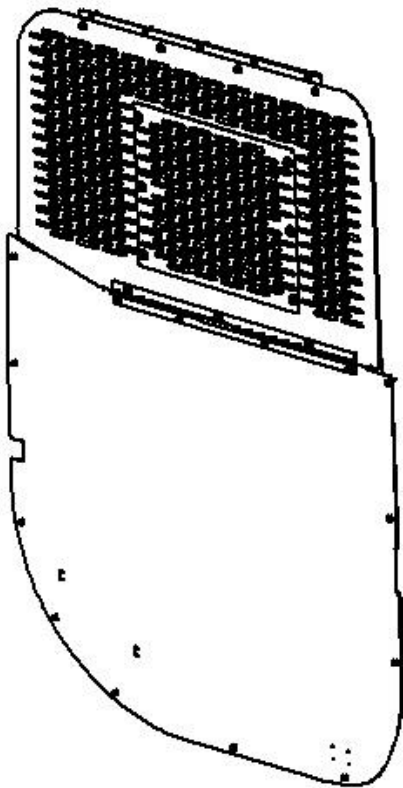

Driver Side window guard & door panel
21238 – Window guard
14605 – Door panel - White
24242 – Door panel - Black

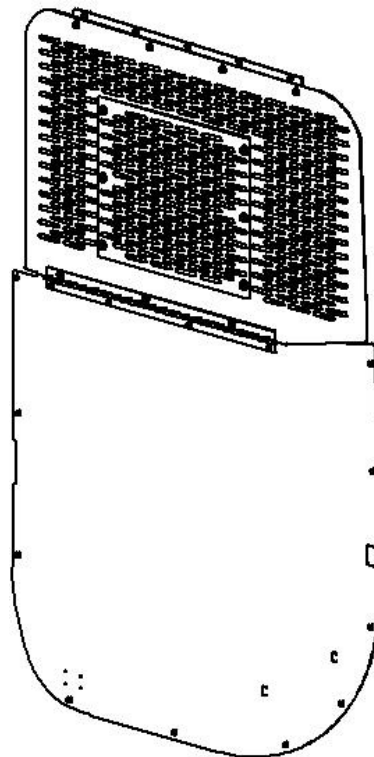

Passenger Side window guard & door panel
21239 – Window guard
14619 – Door panel - White
24243 – Door panel - Black

K9-F23-PT

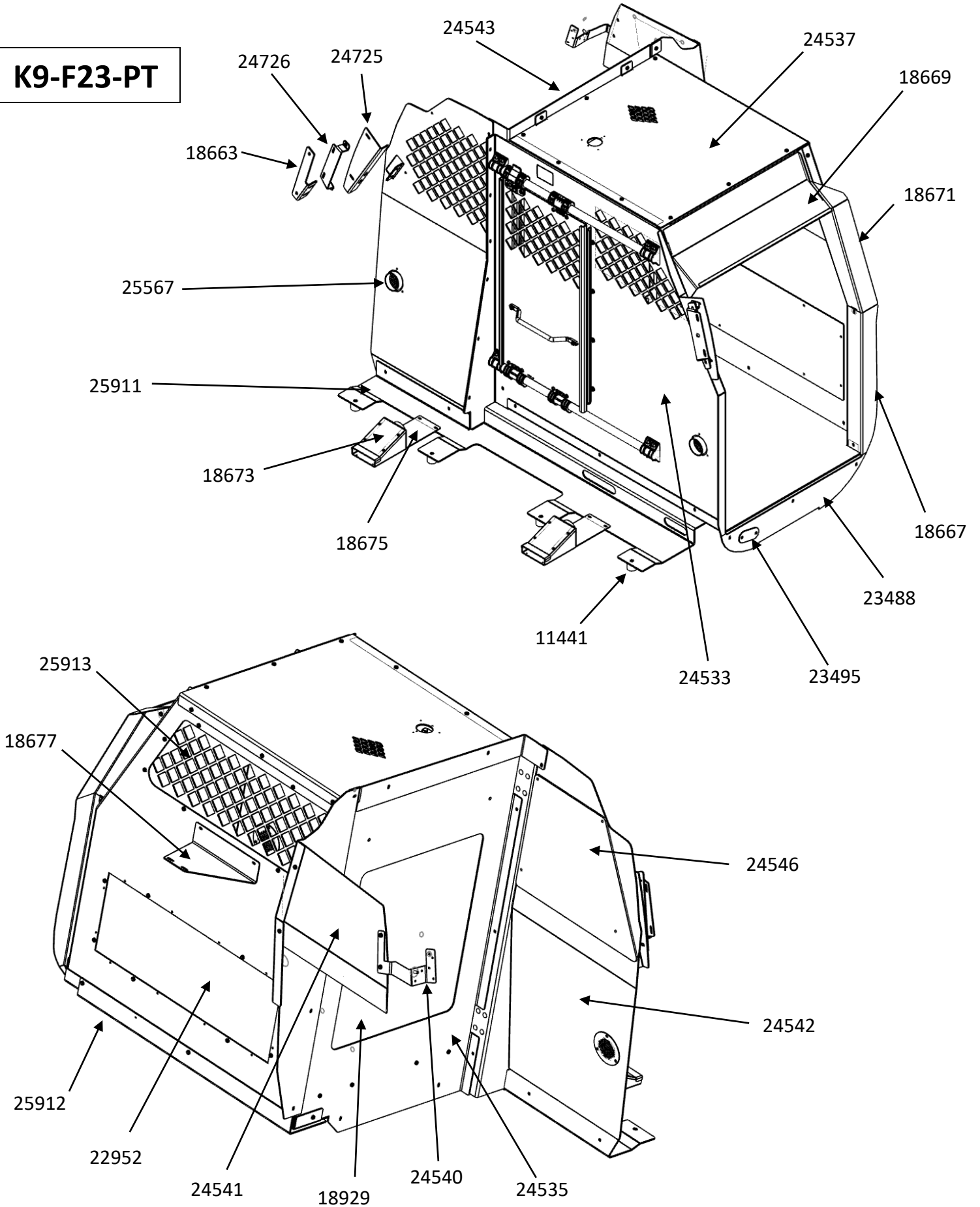



Remove rear passenger door panels first.



Remove two (2) bolts behind access cover in middle of door panel. (10mm socket)

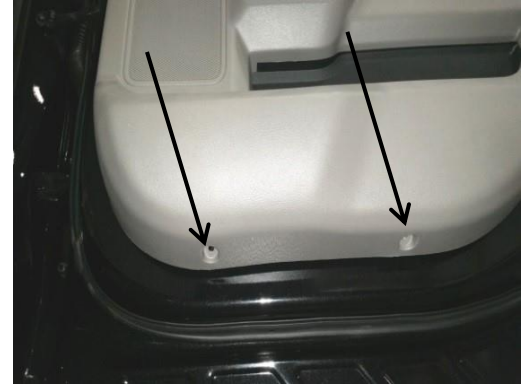

Remove two (2) screws at the bottom of the door panel. (7mm socket)



Remove two (2) bolts behind access cover located behind grab handle. (10mm socket)
Carefully pull off door panel.



Disconnect door latch cable and lock pin. Remove speaker. (7mm socket) Remove window switch from door panel and set aside.

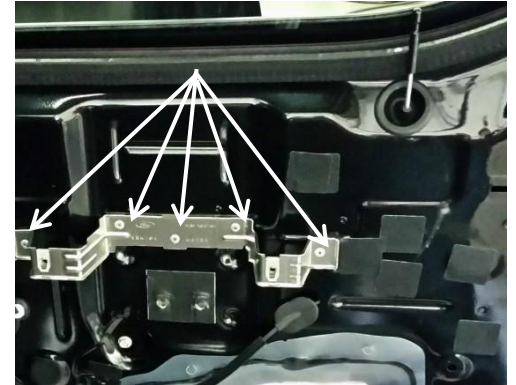

Remove factory metal bracket by drilling out five (5) rivets.
NOTE: Make sure the window is up before drilling into the door panel.



Optional door pop solenoid shown in a mounting location.



The window switch must remain plugged in for proper operation. Taping the switch to the interior side of vapor barrier or wrapping in plastic bag is recommended to avoid problems with future moisture issues.



Hook new door panel on the weather stripping and centering it on the door. Attach panel with # 10 x 1/2" Phillips pan head sheet metal screws.



NOTE: Window guards are shipped flat. On the edge of a work bench, bend a contour in the middle of the guard so it will fit tight against the window frame.



Align the hinge mounting holes to holes in the door panel. Attach hinge with # 10 x 1/2" Phillips pan head sheet metal screws.



With upper mount bracket attached to window guard, mark mounting hole locations on upper door / window frame. Drill 5/32" holes and attach with # 10 x 1/2" flat head sheet metal screws.



NOTE: Before closing door, double check the lock and window operation several times
Door panel shown with sensor for optional NoK9 left behind feature.



Follow the same installation process for the driver side door.
NOTE: Run wiring for optional K9-A-104 prior to door panel installation.



Double check the hinge down / window cleaning feature by removing the four (4) machine screws at the top.



Attach optional 10" fan and fan mount to window guard with 1/4" hardware and spacers as per the instructions provided in the **K9-A-104** kit.



View of back seats before removal. Flip up seats and remove optional power inverter. Save hardware for remounting in the new location. Fully remove the rear seats and driver and middle seat belts.

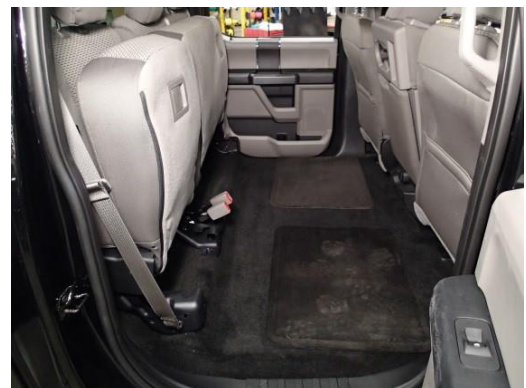

Note: Seat belts must be plugged back into OEM harness (to original plug location). Wire tie seat belts in out of the way location prior to K9 floor being installed.



To remove the back seat, the release switch must be engaged.

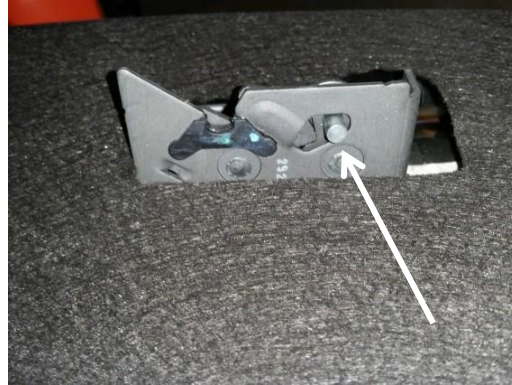

Another view of the release switch



View of back of truck with all seats and optional storage box removed.
Note: If Equipped - Optional OEM inverter must be relocated as desired by installer.

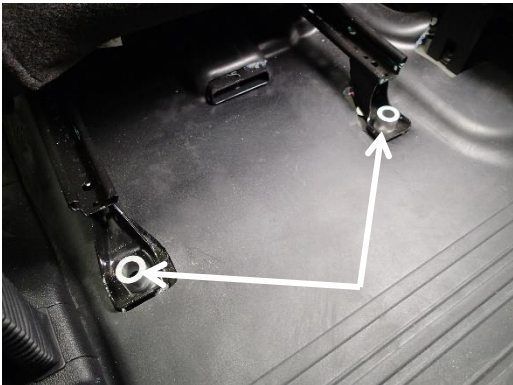

Remove the front seat rear bolts and place the provided 11441 spacers on the seat mount holes.



Install the front mounting bracket by lining up to the holes for the seat bolts. Re-install previously removed seat bolts and tighten.



Slide floor vent adaptor over factory blower vent under seat.
One each side.



Attach adaptor to front floor bracket using two (2) CM86508 #8 x 3/8" Torx head sheet metal screws.

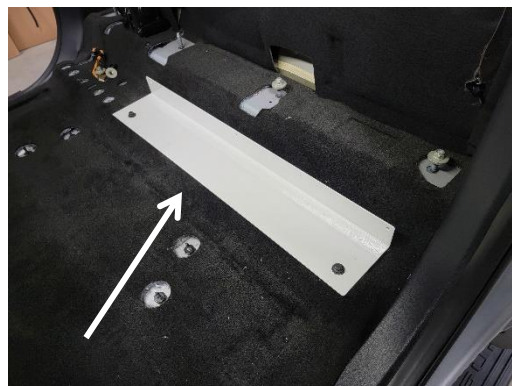

Install the rear mounting bracket with the flange towards the rear. Attach with previously removed seat bolts.



Remove the factory grab handles by gently prying off bolt covers. Remove two (2) M6 bolts (7mm socket)
Repeat process for passenger side



Install upper mounting bracket using previously removed M6 hardware.



On the 2021+ F-150, remove the OEM "B" pillar trim and OEM handle. Attach inner K9 bracket to "B" pillar using previously removed OEM handle hardware.



Reinstall previously removed OEM "B" pillar trim.

Repeat process for passenger side.



Attach outer K9 handle bracket to inner K9 handle bracket using 1/4" x 3/4" Hex head bolts and washers.



Attach floor to the front base mounting bracket using four (4) 1/4" x 3/4" carriage bolts and serrated nuts. *Access to the center bolts is available through the slots in the bracket.*



Attach rear wall and floor to the floor bracket using 1/4" x 3/4" Phillips pan head bolts and washers



Attach front wall to "B" pillar brackets using 1/4" x 3/4" carriage bolts and serrated nuts.



Attach front wall to floor using 1/4" x 3/4" carriage bolts and serrated nuts.



Place divider wall in truck and line up to floor and front bulkhead.



Make sure lower floor tab is on outside edge of divider.



Attach to floor using 1/4" x 3/4" Phillips head bolts and flat washers.



Attach the ceiling to the front and rear walls with 1/4" x 3/4" Phillips head bolts and flat washers.



Attach side rear filler panel using 1/4" x 3/4" Phillips head bolts and flat washers.



Place prisoner compartment bulkhead into truck and line up to center divider. Attach to divider using 1/4" x 3/4" carriage bolts and nuts.



Attach bulkhead to lower floor mounting bracket using 1/4" x 3/4" carriage bolts and nuts.



Attach upper filler panel to divider wall using 1/4" x 3/4" Phillips head bolts and flat washers.

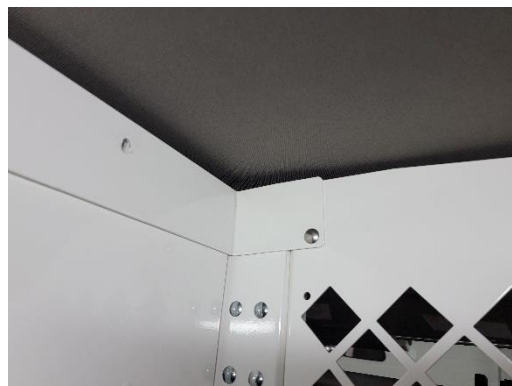

Attach filler to front bulkhead using 1/4" x 3/4" carriage bolt and nut.



Pull back (C) pillar trim from passenger, rear of truck and line up bracket. Bracket should line up with existing hole in metal frame. Drill and attach using (3) 10 x 1/2 Phillips pan head sheet metal screws.

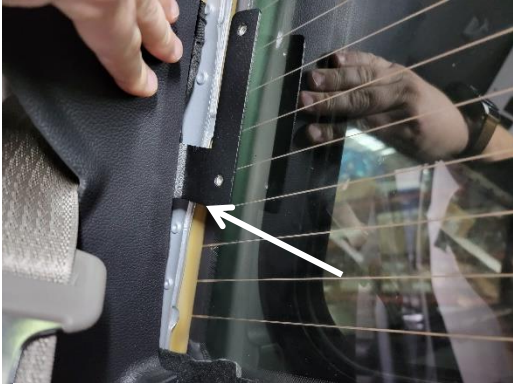

Place trim back over bracket.



Mark section of trim to be notched to allow clearance for bracket.



Snap trim back into place once clearance notch has been cut.



Install rear window guard between rear filler panel and C pillar bracket using 1/4" x 3/4" Phillips head bolts and flat washers.



Reinstall passenger, rear seat using OEM hardware.



Loosely attach K9 lower side filler panel to rear wall with 1/4 x 3/4 Phillips pan head bolts and washers.



Loosely attach K9 upper side filler panel to rear wall with 1/4 x 3/4 Phillips pan head bolts and washers.



Loosely attach K9 upper filler panel with 1/4 x 3/4 Phillips pan head bolts and washers. Install one (1) carriage bolt and nut to front wall.

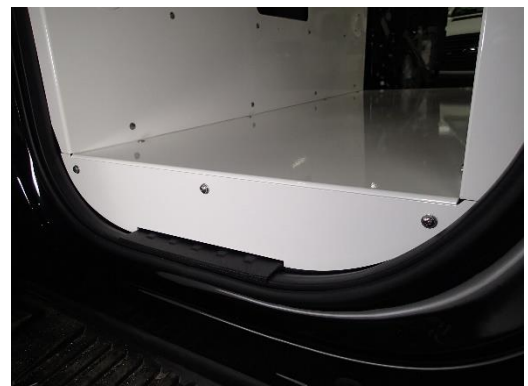

Install lower side panel into floor using 1/4 x 3/4 Phillips pan head bolts and washers.



Attach round vent adaptor to front wall using three (3) #10 x 1/2" flat head screws and keps nuts.



View of vent adaptor from front side.



Attach supplied vent hose to vent adaptors with supplied hose clamps. Hose needs to be cut into two (2) 3 foot pieces.



Secure the vent hose to the bottom corner of the floor bracket using supplied 15" wire tie.



Attach the upper rear support bracket to holes in rear wall and to OEM threaded holes with previously removed seatbelt hardware.



Attach rear window screen using 1/4 x 3/4 Phillips pan head bolts and washers.



Attach lower rear access cover using 1/4 x 3/4 Phillips pan head bolts and washers.

Note: Optional PT-A-906 is available to fit this location if desired.



Attach emergency exit door to rear divider with two (2) knobs. Silicone floor are seams and let dry before placing in rubber floor mat.



Installation is now complete.