

K9-F28-PT INSTALLATION INSTRUCTIONS

K9 & PRISONER TRANSPORT KIT for 2020-2023 FORD INTERCEPTOR UTILITY

TOOLS Needed:

Phillips Screw Driver	Trim panel removal tool	Caulk Gun	Drill & drill bits
Standard Socket set	Wire Cutters /Crimpers	Metric Socket set	1.5" hole saw

PARTS & HARDWARE:

<u>QTY</u>	<u>DESCRIPTION</u>	<u>PART # White</u>	<u>PART # Black</u>
1	Front bulkhead with sliding door	18903	18904
2	Lower "B" pillar bracket		18848
2	Upper "B" pillar bracket		18849
1	Rear bulkhead	24069	24070
1	Rear bulkhead reinforcement bracket	18846	18847
1	Rear perforated diamond section		18915
1	Center divider wall	18948	18949
1	Front floor section		18902
1	Passenger side floor step	18805	18806
1	Hot-N-Pop gas spring hole cover	18858	18859
1	Angled rear floor section		18917
1	Front floor bracket		18920
1	Middle floor bracket		18921
1	Rear floor bracket		18798
1	Rear cargo trim cover		18877
1	Ceiling	18908	18909
1	Ceiling air duct vents	18517	18518
1	Passenger side rear wall	18827	18828
1	Passenger side upper rear filler	18835	18836
1	Passenger side upper ceiling filler	18843	18844
1	Passenger side lower filler	18819	18820
1	Driver front partition	18918	18919
1	Lower divider wall filler	18922	18923
1	Upper divider wall filler	18924	18925
1	Lower divider filler support bracket	18926	18927
1	Rear seat lower filler	18934	18935
1	Front divider wall lower filler	18943	18944
1	Electronics access cover	18856	18857
1	Driver side door panel (DP-F28-1A)	14607	14608
1	Passenger side door panel (DP-F28-6A)	14621	14622
1	Driver seat lower bracket		18939
2	Speaker cover		14628
1	Driver side hinged window guard (WGI-F28-1-K9)		21249
1	Passenger side hinged window guard (WGI-F28-6-K9)		21250
1	Rubber Mat		18928
1	Mount bracket for Whelen Cencom box		18882
1	Lexan filler cover	18931	
6	Rubber bumpers	13691	
1	Dome Light Kit	K9-A-106	
36	1/4" serrated flange nut	16086	
8	1/4" Acorn nut	16114	
44	1/4" x 3/4" Carriage bolt – SS	16235	
55	1/4" x 3/4" Phillips pan head screw - SS	16618	
63	1/4" Flat washer - SS	16154	
2	5/16" Flat washer	16123	
2	5/16" x 1.25" Screw	16337	
3	#10 x 1/2" Screw	16655	
1	Silicone caulk (sealant)	20011	20012

Installation Notes:

- Read all instructions before installing any Havis, Inc. products.
- Use hardware provided with install kit.

Vehicle Note:

For K9 applications, it is always recommended to order the Interceptor Utility with the OEM optional Aux Rear Air conditioning. (Ford option code 17A)

K9-F28-PT Assembly

Part numbers for white parts shown

Door panels and window guards not shown

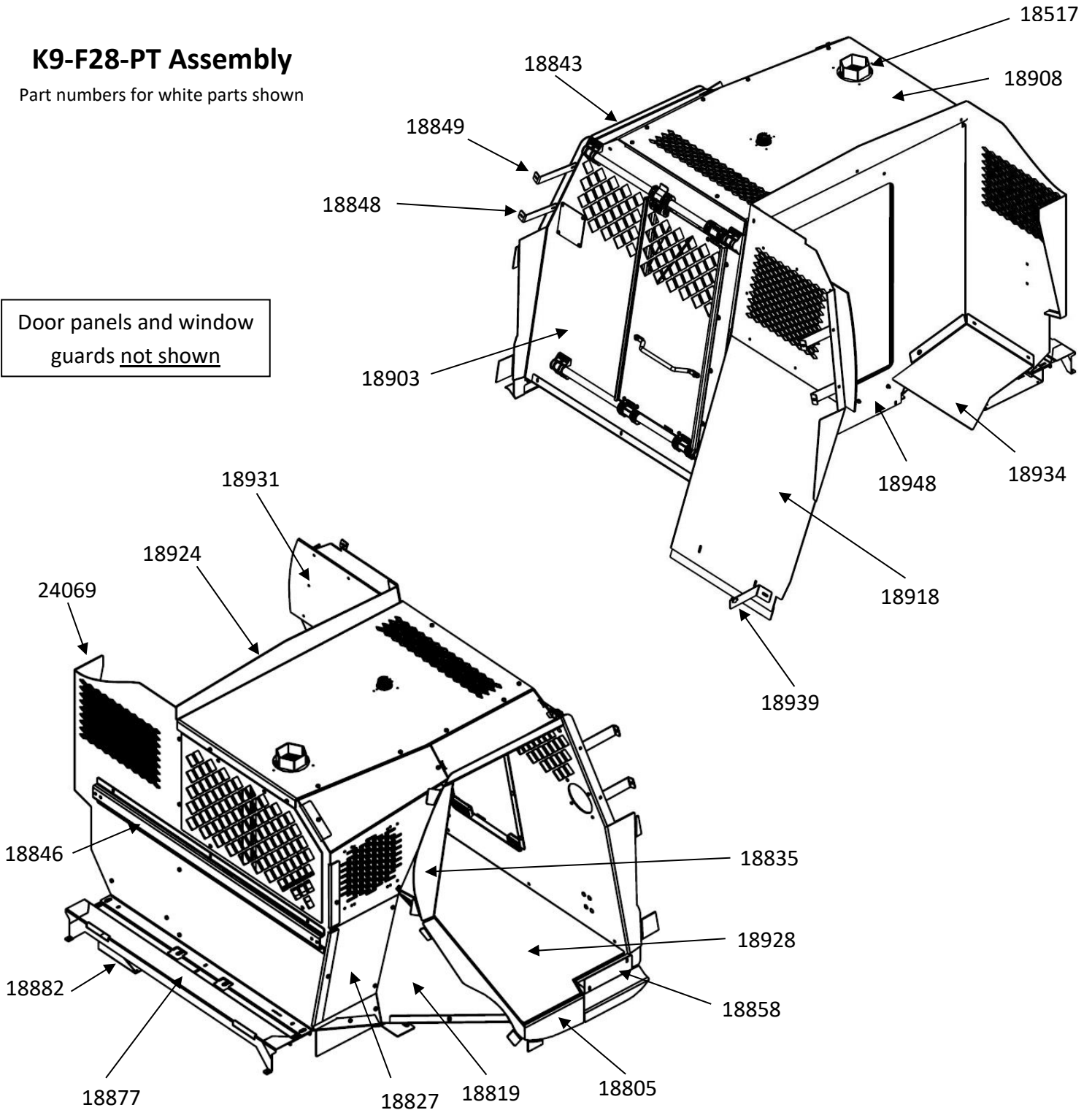



Remove rear passenger door panels first. Behind the door open paddle handle and grab handle, remove plastic cover and 10mm head bolts. Remove two 7mm head fasteners from bottom of door.

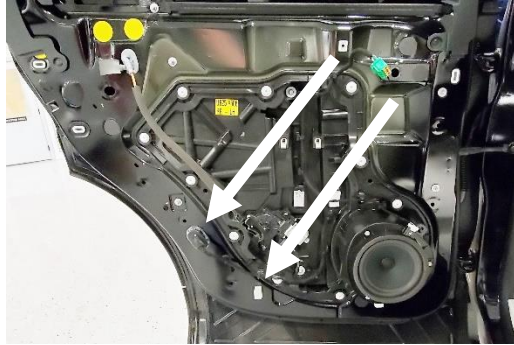

Remove (2) plastic screw retainers from bottom of door. These will not be reused. **Note: Push in oval grommet with wire harness so K9 door panel lays more flat when screwed on. Make sure harness does not interfere with internal door parts.**

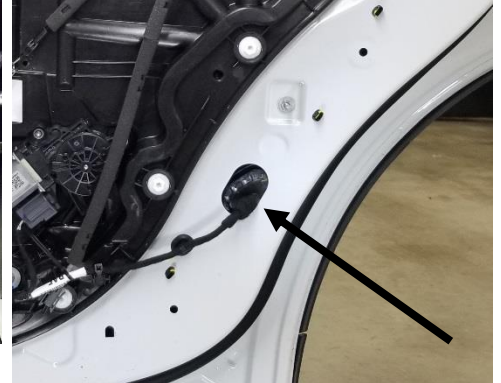

Push large grommet with harness into door cavity to allow K9 door panel to lay closer against door.



Place K9 kit door panel onto door. The top will hook onto rubber molding. Position so it lines up with the two existing (protruding) bolts. Drill mounting holes with 1/8" drill bit. Attach door panels with supplied #10 x 1/2" Phillips pan head sheet metal screws. **Check remote door unlock feature before closing door.**



NOTE: Window guards are shipped flat. On the edge of a work bench, bend a contour in the middle of the guard so it will fit tight against the window frame.

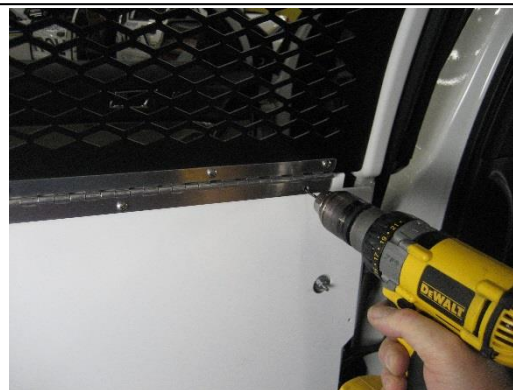

Position window guard with hinge assembly inside window frame and attach hinge to door panel pre-punched holes with supplied # 10 x



With upper mount bracket attached to window guard, mark mounting hole locations in upper door / window frame. Drill 5/32 holes. Attach upper mount bracket with supplied #10 x 1/2 Phillips flat head sheet metal screws.



Remove back seats and set aside.
Hardware will be reused.

**Note: The driver side rear seat will be
will also be reused / reinstalled.**

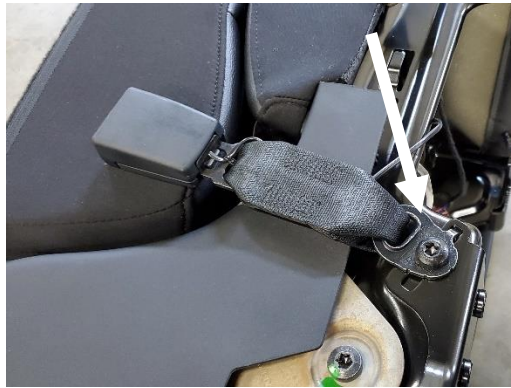

The seat belts on the back seats have sensors built into them that will turn on an indicator on the dash. They will need to be removed from the two (2) unused OEM seats. (T-50 Torx)



Locate the three harnesses for the rear seat belts.

Note: Driver side rear seat belt sensor wire will be plugged in when seat is reinstalled.

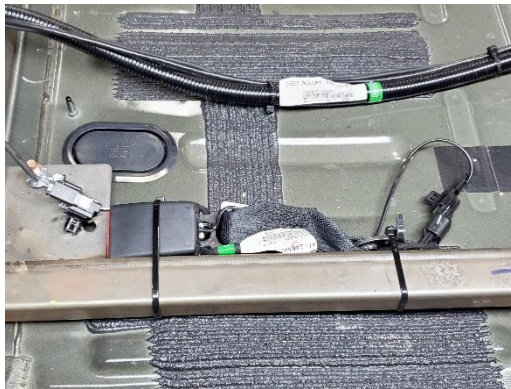

Simply wire tie the removed seat belts to the side of OEM cross brace and plug harnesses back in.



Remove rear floor sections and forward foam block from back of SUV.

A T-55 Torx socket is needed for the forward bolts.

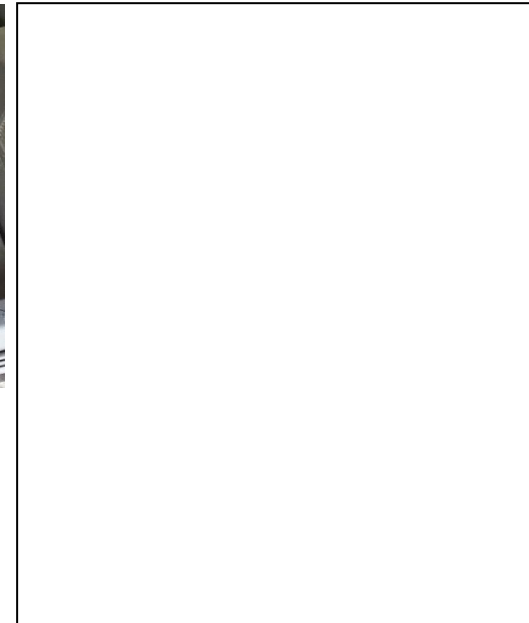

Remove passenger sill plate.
This will not be reused.

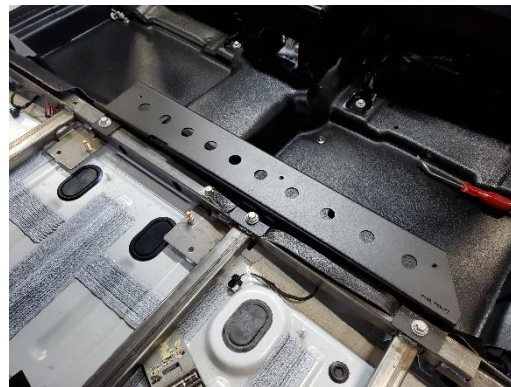

Use OEM seat bolts to attach K9 kit front floor bracket to OEM seat mount locations.

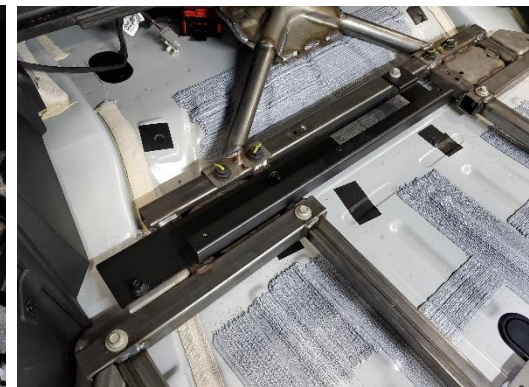

Use OEM nuts to attach K9 kit middle floor support bracket to OEM cross brace.



Attach rear floor bracket using previously removed T-55 Torx bolts.

Note: Run wiring for dome light, rear fan and other equipment prior to installing floor.



Place floor into rear of SUV and loosely attach to front and middle floor brackets using 1/4" x 3/4" Phillips pan head screws and flat washers.

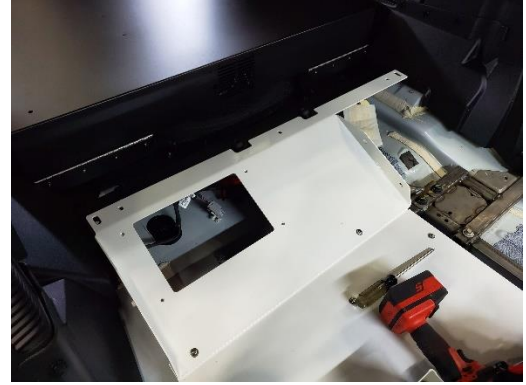

Place rear angled floor section into vehicle and loosely attach to forward floor, and rear bracket using 1/4" x 3/4" Phillips pan head screws and flat washers.

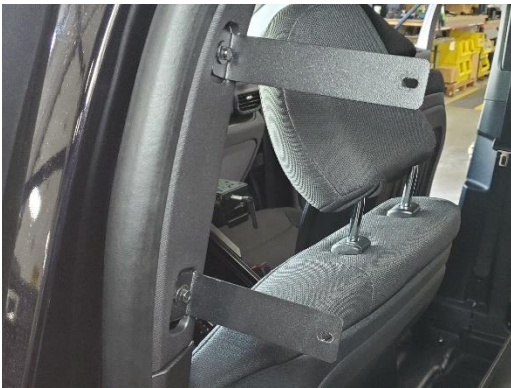

Prior to front bulkhead installation, remove OEM "B" pillar grab handles. Attach upper front bulkhead "L" brackets to "B" pillar with OEM grab handle screws. (Longer bracket goes on top with "L" flange facing out) Do the same for both sides.



Place K9 front bulkhead into vehicle. Take care not to scratch floor when sliding bulkhead into position.



Loosely attach K9 front bulkhead to "B" pillar brackets with 1/4 x 3/4 carriage bolts and serrated flange nuts. Bracket goes on inside of bulkhead flange.



Place rear bulkhead into vehicle and line up to rear floor section.



Attach rear bulkhead to rear floor bracket using (3) 1/4" x 3/4" carriage bolts and serrated nuts. **Note:** Rear bulkhead no longer has removable rear guard.



Also attach rear bulkhead to rear floor bracket outboard holes using (2) 5/16" x 1.25" bolts, washers, and nuts.



Place divider wall into vehicle and line up to passenger side front and rear bulkhead.



Attach divider to bulkheads using 1/4" x 3/4" carriage bolts, Phillips bolts, and washers.



Place ceiling on top of front and rear bulkheads. Loosely attach ceiling to rear bulkhead with 1/4" x 3/4" pan head Phillips bolts and flat washers.



Attach K9 side wall to kit and using 1/4" x 3/4" pan head Phillips bolts and flat washers.

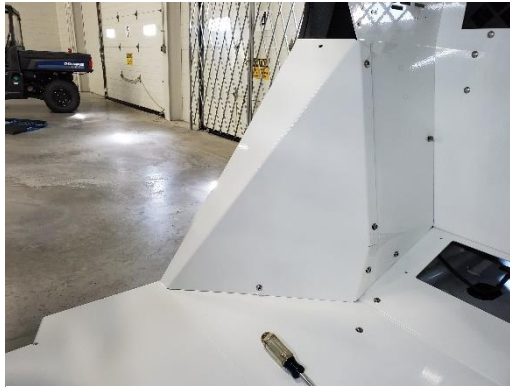

Attach K9 lower filler into kit using 1/4" x 3/4" pan head Phillips bolts and flat washers.



Attach K9 upper rear filler to kit using 1/4" x 3/4" pan head Phillips bolts and flat washers.



Attach K9 upper trim into kit using 1/4" x 3/4" pan head Phillips bolts and flat washers.



Place the prisoner partition into vehicle and attach using 1/4" x 3/4" carriage bolts and serrated nuts.



Attach partition to previously installed "B" pillar brackets using 1/4" x 3/4" carriage bolts and serrated nuts.



Attach upper trim panel to center divider and front bulkhead using (3) 1/4" x 3/4" carriage bolts and serrated nuts.



Attach lower support bracket to OEM hole in driver seat base and to bulkhead using (2) 1/4" x 3/4" carriage bolts and nuts.



Attach lower filler to divider using 1/4" x 3/4" pan head Phillips bolts and washers.



Attach lower divider filler support bracket using (2) 1/4" x 3/4" Phillips head bolts and washers.

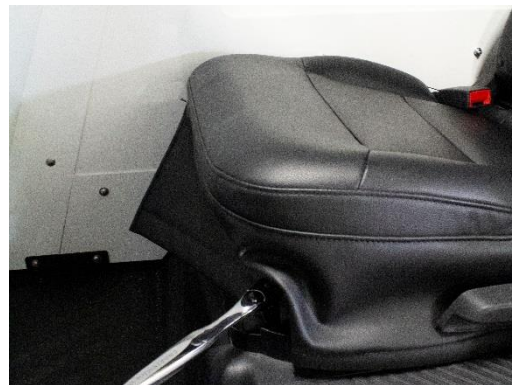

Re-install seat with OEM hardware and torque to manufacturers specifications.

Note: Make sure to plug seat belt sensor wire back into harness.



Install lower filler behind rear seat using (3) 1/4" x 3/4" pan head Phillips bolts and washers.

Note: Add optional K9-A-111 Cencom bracket before installing filler.

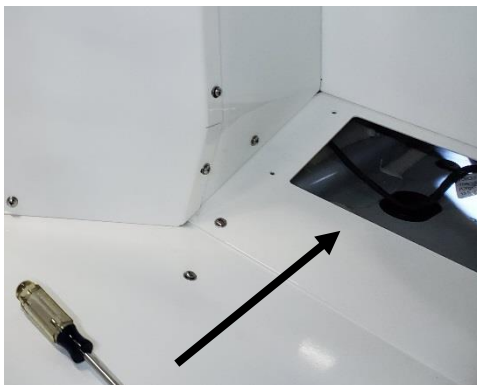

Attach passenger side electrical access cover to K9 floor using 1/4" x 3/4" Phillips pan head screws and flat washers.



Check and tighten all hardware where previously left loose.



Install center emergency exit pass through door by placing on bottom support and securing at top studs using (2) 1/4" knobs.



Confirm smooth slide and lock functionality of front egress door.



Neatly silicone / caulk the lower seams to shed water out of vehicle. Let silicone dry overnight prior to installing rubber mat



Example front bulkhead mounting location for the optional air circulation fan.
K9-A-102



Driver side window guard with optional 10" fan mount kit shown.

Fan and window mount kit part number **K9-A-104**

****Kit includes K9-A-301 fan and WG1007335 mount with hardware****

K9-A-104 also works on Passenger side window guard



Installation is now complete.