

INSTALLATION INSTRUCTIONS

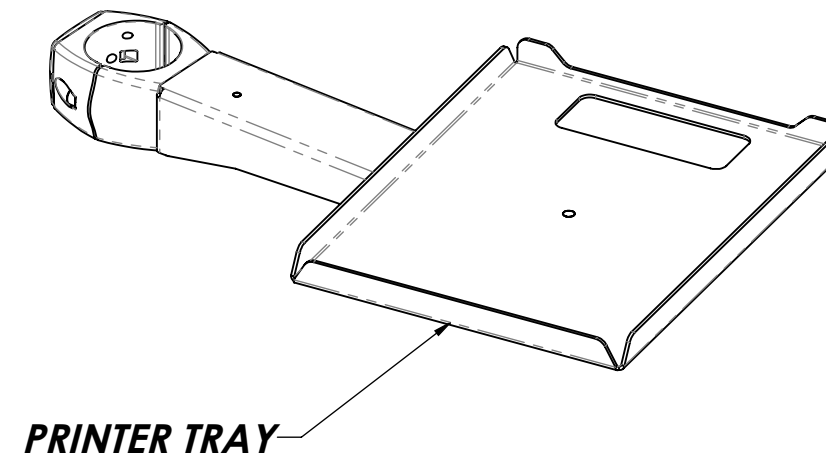
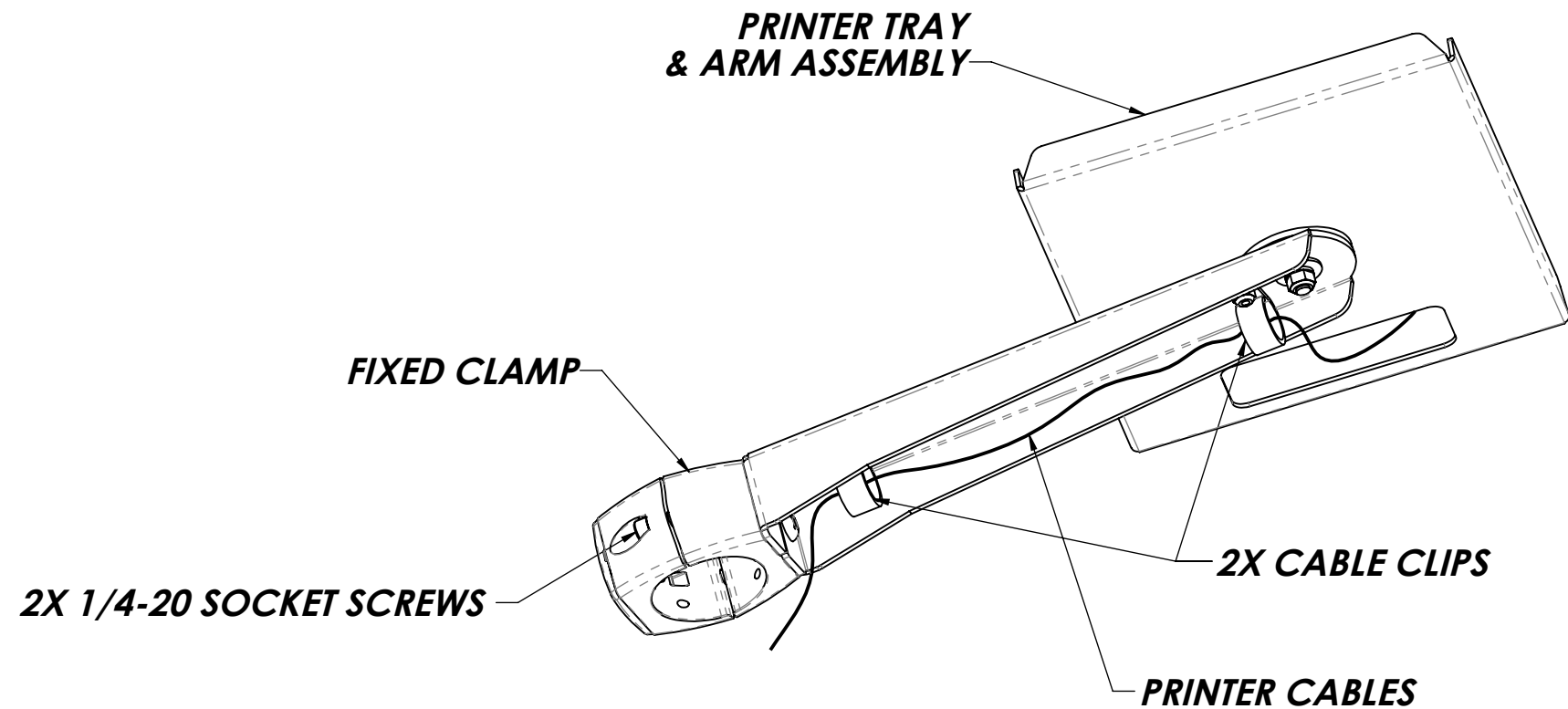

TOOL LIST:

3/16 HEX WRENCH (PROVIDED)

ASSEMBLY STEPS:

1. SLIDE THE **PRINTER TRAY & ARM ASSEMBLY** ONTO THE CUSTOMER'S POLE THEN TIGHTEN THE **2X 1/4-20 SOCKET SCREWS** TO SECURE AT DESIRED HEIGHT.
2. PLACE PRINTER ONTO THE **PRINTER TRAY**.
3. ROUTE **PRINTER CABLES** THROUGH **2X CABLE CLIPS** AS SHOWN.

THE INFORMATION CONTAINED IN THIS DRAWING IS THE SOLE PROPERTY OF HAVIS AND REPRODUCTION IN PART OR IN WHOLE WITHOUT THE WRITTEN PERMISSION OF HAVIS IS PROHIBITED.

A	RELEASED FOR PROTOTYPE	09/24/14	JVT	CDB
REV.	DESCRIPTION	DATE	BY	CHK'D
	DRAWN J. TERVEER	09/24/2014		
	CHECKED			
	DATE			
	DO NOT SCALE DRAWING			
	MATERIAL SEE B.O.M.			
	FINISH N/A			
TITLE		HAVIS		
CUSTOMER INSTALLATION, PRINTER TRAY WITH ARM, FIXED CLAMP, FOR Ø2.00 POLE		SIZE	DWG. NO.	REV.
		B	367-3161	A
		SHEET 1 OF 1		