

INSTALLATION INSTRUCTIONS

TOOL LIST:

1. #2 PHILLIPS SCREW DRIVER OR DRILL DRIVER

NOTES:

1. INSTALL THE **MOUNTING PLATE WITH ADHESIVE PAD** TO THE **ENS SWIVEL STAND** USING THE **4X #10-32 X 1.00" LONG PHILLIPS FLAT HEAD SCREWS** AS SHOWN.
2. FOR STAND INSTALLATION SEE THE **CUSTOMER INSTRUCTIONS THAT WERE PROVIDED WITH THE ENS SWIVEL STAND.**

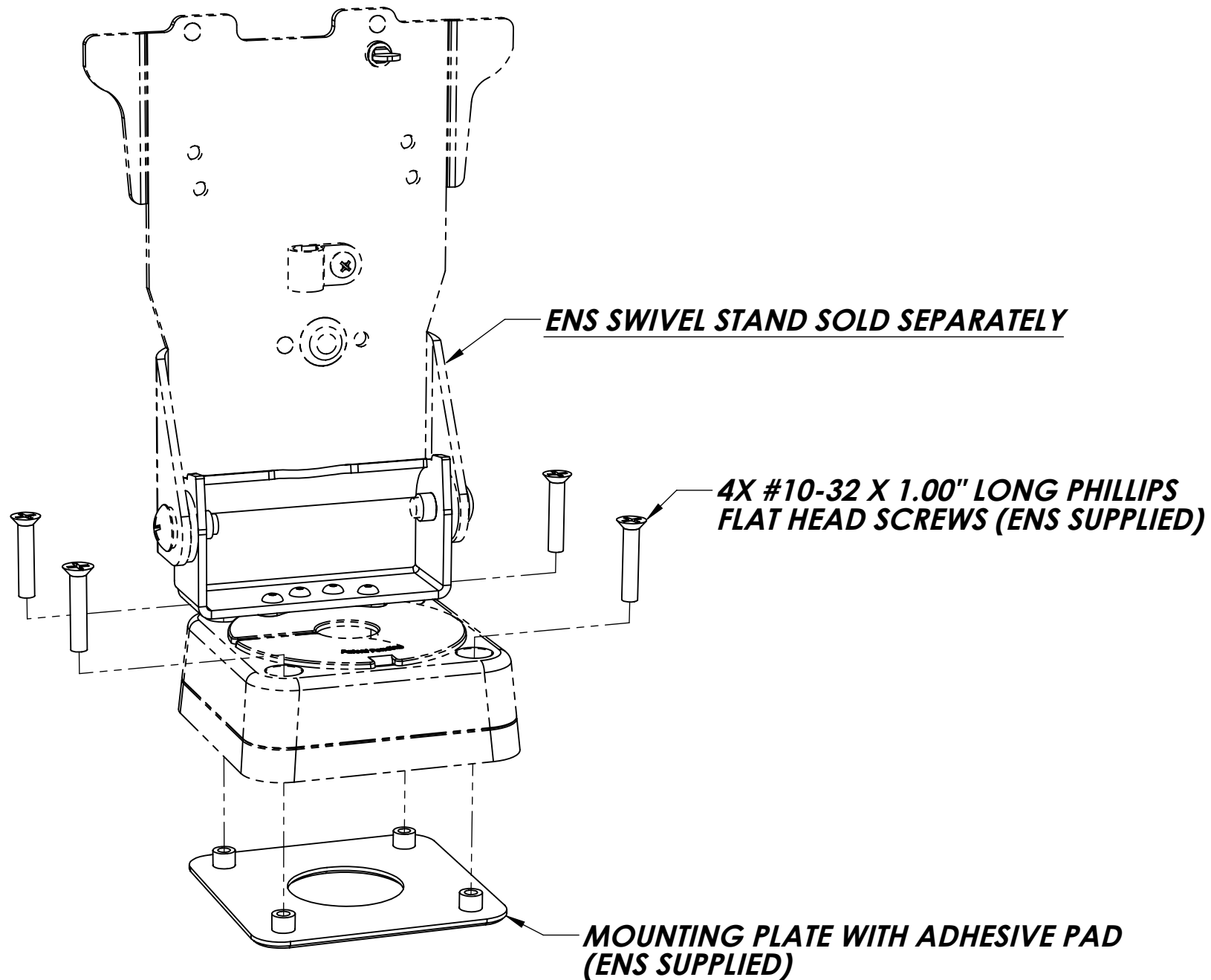

| | |
|---|---------|
| DIMS. AND TOLERANCES PER ASME Y14.5 - 1994 | |
| UNLESS OTHERWISE SPECIFIED DIMENSIONS ARE IN INCHES TOLERANCES ARE: | |
| FRACTIONAL | ± 1/32 |
| 2 PLC. DEC. | ± .03 |
| 3 PLC. DEC. | ± .010 |
| ANGULAR | ± 0°30' |

THE INFORMATION CONTAINED IN THIS DRAWING IS THE SOLE PROPERTY OF HAVIS AND REPRODUCTION IN PART OR IN WHOLE WITHOUT THE WRITTEN PERMISSION OF HAVIS IS PROHIBITED.

| | | | | |
|--|------------------------|----------|----------|--------------|
| B | RELEASED FOR PROTOTYPE | 08/05/13 | JGC | JGC |
| REV. | DESCRIPTION | DATE | BY | CHK'D |
| DRAWN | J. CHRISTOPHERSON | DATE | 10/17/12 | |
| CHECKED | | DATE | | |
| DO NOT SCALE DRAWING | | | | |
| MATERIAL | | | | |
| FINISH | | | | |
| TITLE | | HAVIS | | |
| CUSTOMER INSTRUCTIONS, GLUE PAD SYSTEM, FOR ENS2554 CENTER HOLE SWIVEL SQUARE BASE | | | | |
| SIZE | B | DWG. NO. | 367-2569 | REV. B |
| | | | | SHEET 1 OF 1 |