

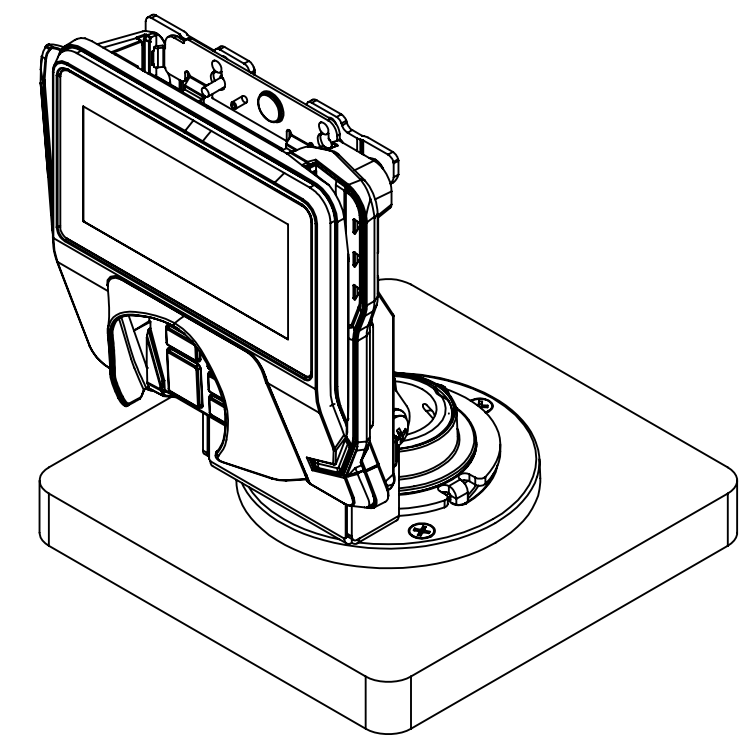
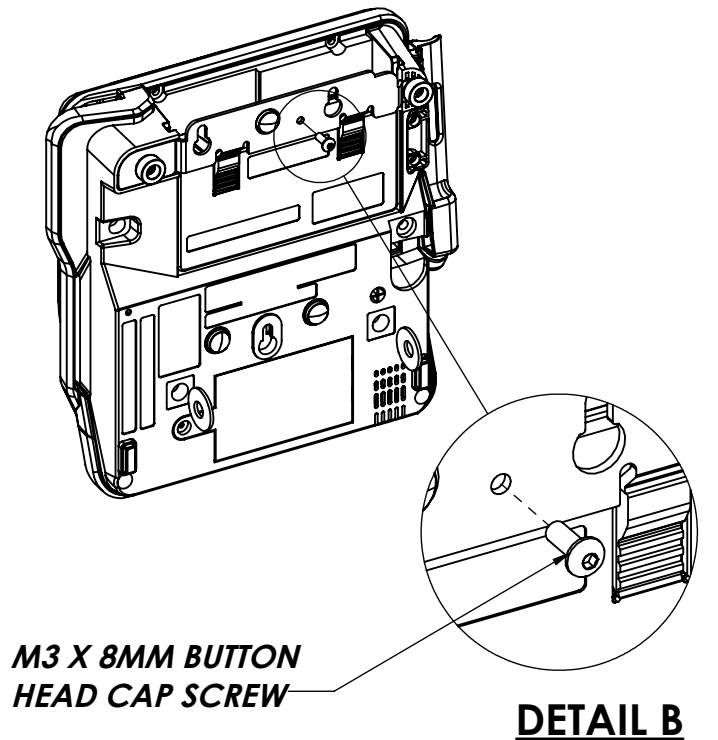

**TOOL LIST:**

1. #2 PHILLIPS SCREW OR DRILL DRIVER
2. 2MM ALLEN WRENCH (PROVIDED)
3.  $\phi 9/64$  DRILL BIT ( $\phi .141$ ") DRILL BIT & DRILL DRIVER

**ASSEMBLY STEPS:**

1. USING THE **SWIVEL BASE STAND** AS A TEMPLATE, ROTATE LEFT/RIGHT TO STOP POINTS TO DETERMINE DIRECTION OF SWIVEL BEFORE MOUNTING.
2. (OPTIONAL) DRILL A 1 3/8" (1.375") THROUGH HOLE INTO YOUR **COUNTER** AS SHOWN.
3. MARK MOUNTING LOCATION ON **COUNTER**
4. DRILL 9/64 HOLES IN MARKED LOCATION ON **COUNTER**
5. ASSEMBLE THE **SWIVEL BASE STAND** TO THE **COUNTER** USING **3X #10 X 1.00" LONG PHILLIPS FLAT HEAD WOOD SCREWS** AS SHOWN.
6. INSTALL THE **M3 X 8MM BUTTON HEAD CAP SCREW** TO THE UNDERSIDE OF THE **CREDIT CARD MACHINE**. AS SHOWN IN **DETAIL B**
7. ASSEMBLE THE **CREDIT CARD MACHINE** TO THE **SWIVEL BASE STAND** BY SLIDING IT ONTO THE **KEYHOLE STANDOFFS** AS SHOWN.
8. THREAD THE **THUMB SCREW** INTO THE **SWIVEL BASE STAND** TO SECURE THE **CREDIT CARD MACHINE** AS SHOWN.
9. ROUTE THE **MACHINE CABLES** THROUGH THE **CABLE CLIP** AND SECURE WITH THE **#8-32 X .25" LONG PHILLIPS SCREW** AS SHOWN.



DWG. NO. 367-3213	REV. B	TITLE LOW CONTOUR STAND 8-90 DEGS CENTER HOLE SWIVEL SMART CARD CLEARANCE VERIFONE MX915/MX925/M424/M425	 SHEET 1 OF 1
DRAWN J. BROWN	DATE 12/12/2014		

REVISIONS				
REV	DESCRIPTION	DATE	BY	CHK'D
F		06/20/16	JVT	JVT

**CUSTOMER INSTRUCTIONS**