

INSTALLATION INSTRUCTIONS

SHEET 1 - SCREW OPTION

(SEE SHEET 2 FOR ADHESIVE PAD OPTION)

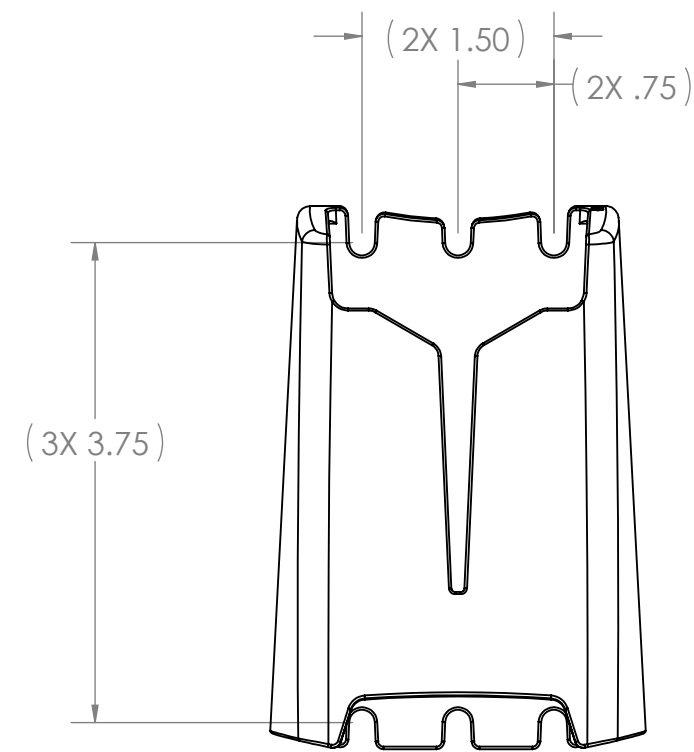

VIEW B

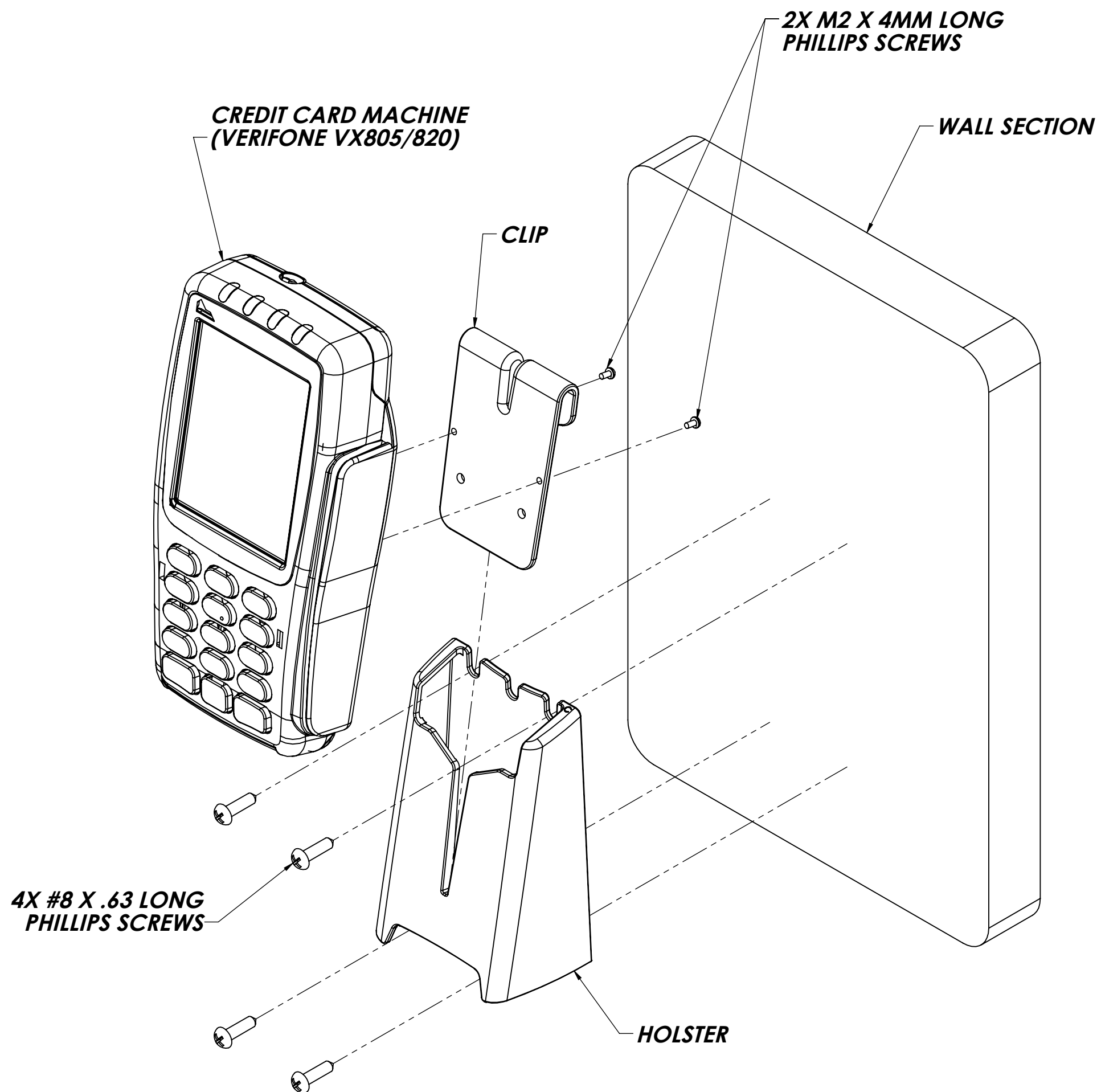
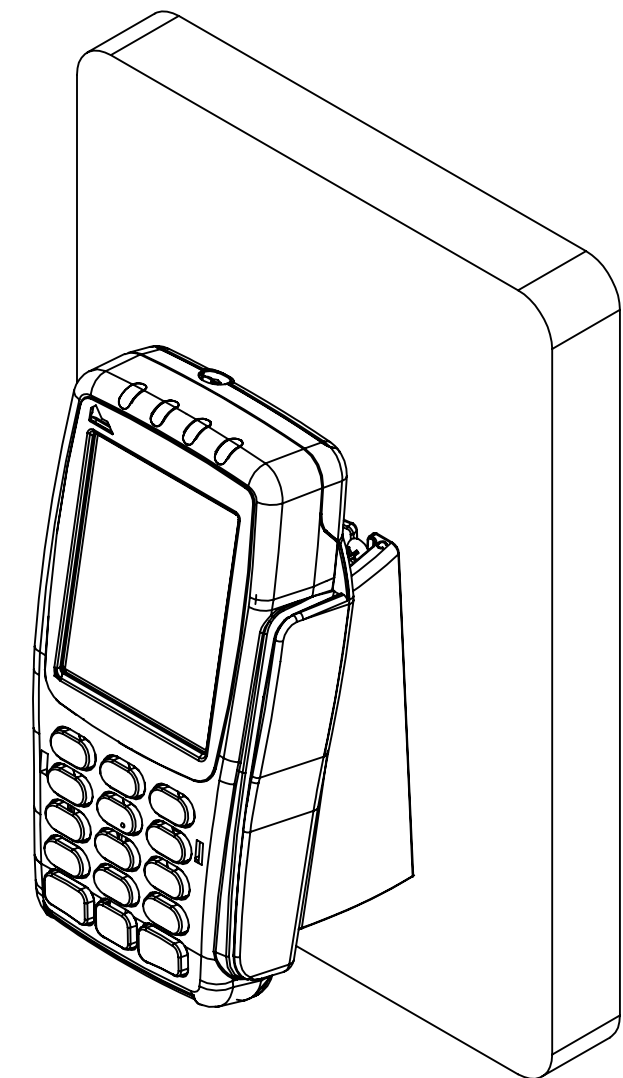

TOOLS LIST:

1. #1 PHILLIPS SCREW DRIVER

ASSEMBLY STEPS:

1. USING THE **HOLSTER** AS A TEMPLATE, MARK AND DRILL .09" DIAMETER HOLES INTO **WALL SECTION**. SEE **VIEW B**.
2. ATTACH **HOLSTER** TO **WALL SECTION** WITH **4X #8 X .63 LONG PHILLIPS SCREWS** AS SHOWN.
3. ATTACH **CLIP** TO **CREDIT CARD MACHINE** WITH **2X M2 X 4MM LONG PHILLIPS SCREWS** AS SHOWN. **DO NOT OVER TIGHTEN.**
4. SLIDE **CLIP** INTO **HOLSTER** AS SHOWN.

THE INFORMATION CONTAINED IN THIS DRAWING IS THE SOLE PROPERTY OF HAVIS AND REPRODUCTION IN PART OR IN WHOLE WITHOUT THE WRITTEN PERMISSION OF HAVIS IS PROHIBITED.

DIMS. AND TOLERANCES PER ASME Y14.5 - 1994 UNLESS OTHERWISE SPECIFIED DIMENSIONS ARE IN INCHES TOLERANCES ARE:		DRAWN S. YANG	09/06/18	JEB	
DATE 3/25/2015		DATE	DATE	BY	CHK'D
CHECKED		CHECKED	 TITLE CUSTOMER INSTRUCTIONS, WALL HOLSTER, PLASTIC, QUICK-RELEASE WITH ADHESIVE PADS AND MOUNTING SCREWS		
FRACTIONAL ± 1/32		DATE			
2 PLC. DEC. ± .03		DO NOT SCALE DRAWING			
3 PLC. DEC. ± .010		MATERIAL SEE B.O.M.			
ANGULAR ± 0°30'		FINISH N/A	SIZE C	DWG. NO. 367-3282	REV. D
			SHEET 1 OF 2		

INSTALLATION INSTRUCTIONS SHEET 2 - ADHESIVE PAD OPTION (SEE SHEET 1 FOR SCREW OPTION)

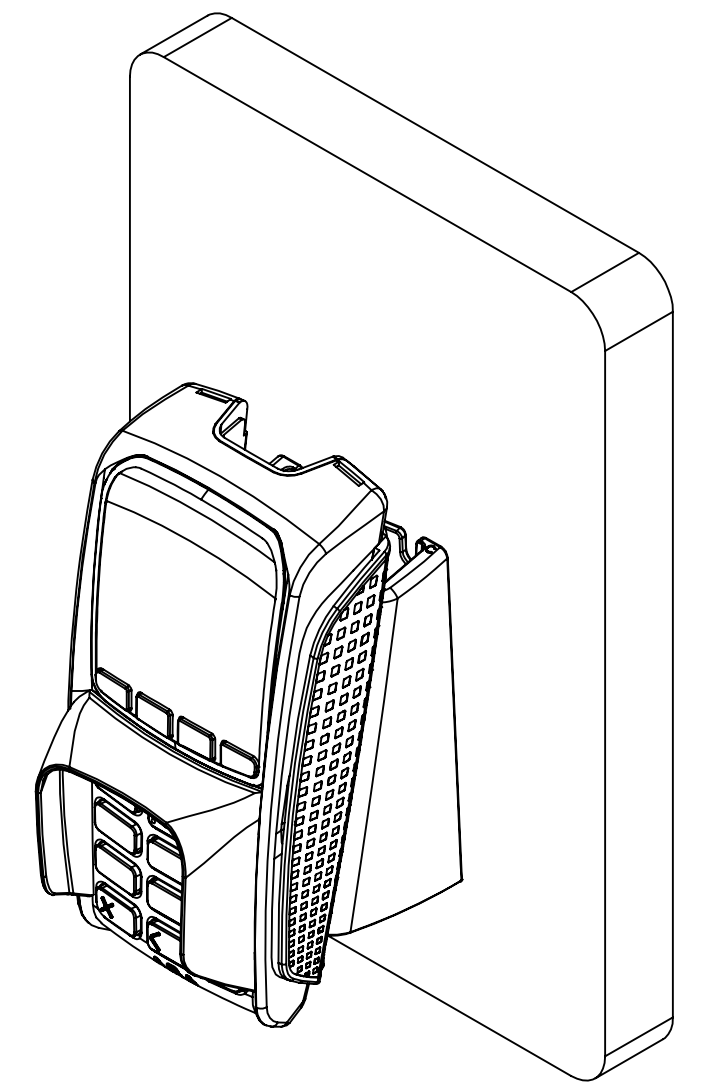
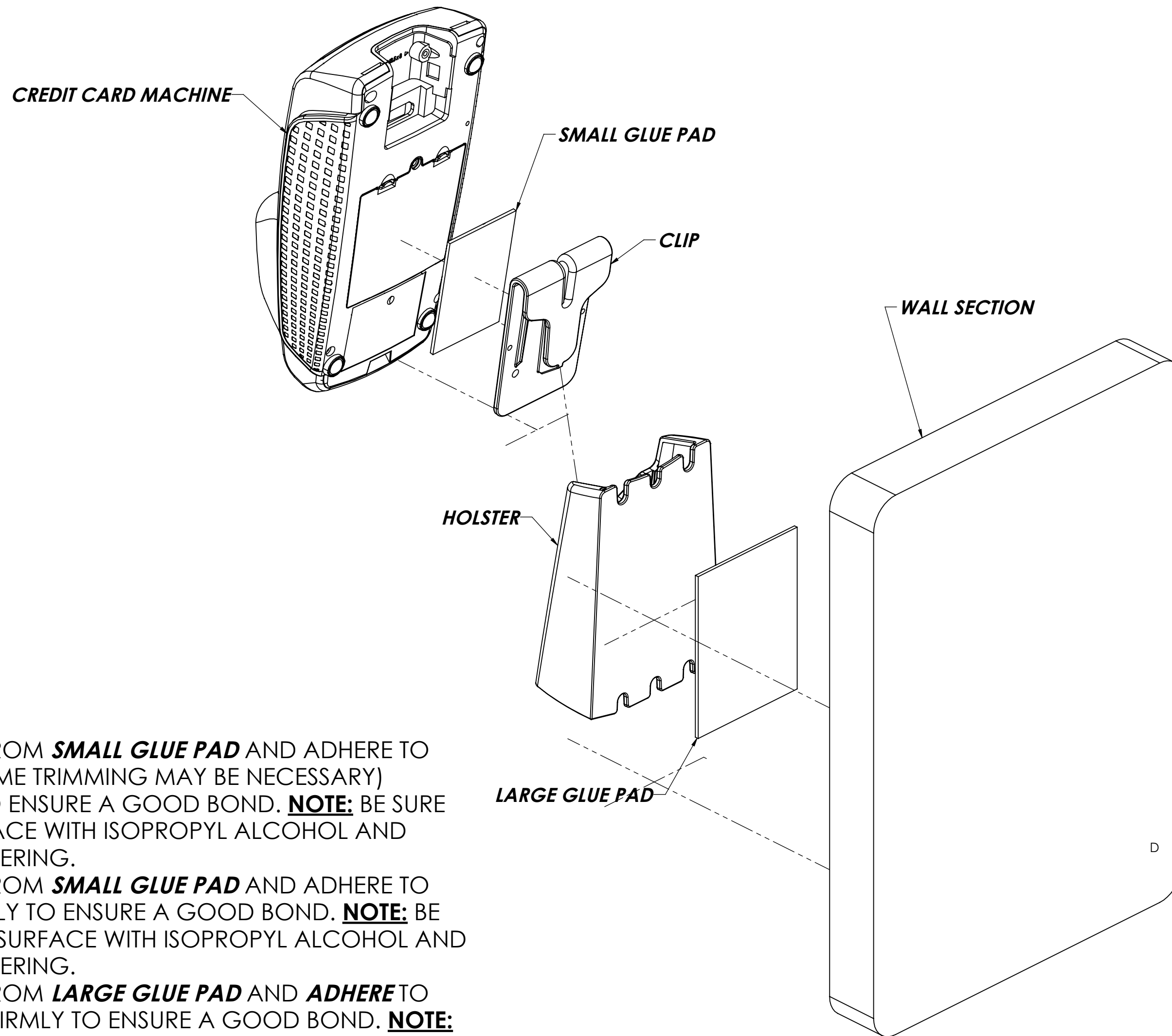

ASSEMBLY STEPS:

1. REMOVE PAPER BACKING FROM **SMALL GLUE PAD** AND ADHERE TO **CREDIT CARD MACHINE** (SOME TRIMMING MAY BE NECESSARY) AS SHOWN. PRESS FIRMLY TO ENSURE A GOOD BOND. **NOTE:** BE SURE TO CLEAN MOUNTING SURFACE WITH ISOPROPYL ALCOHOL AND ALLOW TO DRY BEFORE ADHERING.
2. REMOVE PAPER BACKING FROM **SMALL GLUE PAD** AND ADHERE TO **CLIP** AS SHOWN. PRESS FIRMLY TO ENSURE A GOOD BOND. **NOTE:** BE SURE TO CLEAN MOUNTING SURFACE WITH ISOPROPYL ALCOHOL AND ALLOW TO DRY BEFORE ADHERING.
3. REMOVE PAPER BACKING FROM **LARGE GLUE PAD** AND **ADHERE** TO **HOLSTER** AS SHOWN. PRESS FIRMLY TO ENSURE A GOOD BOND. **NOTE:** BE SURE TO CLEAN MOUNTING SURFACE WITH ISOPROPYL ALCOHOL AND ALLOW TO DRY BEFORE ADHERING.
4. REMOVE PAPER BACKING FROM **LARGE GLUE PAD** AND **HOLSTER** TO **WALL SECTION** AS SHOWN. PRESS FIRMLY TO ENSURE A GOOD BOND. **NOTE:** BE SURE TO CLEAN MOUNTING SURFACE WITH ISOPROPYL ALCOHOL AND ALLOW TO DRY BEFORE ADHERING.
5. SLIDE **CLIP** INTO **HOLSTER** AS SHOWN.

THE INFORMATION CONTAINED IN THIS DRAWING IS THE SOLE PROPERTY OF HAVIS AND REPRODUCTION IN PART OR IN WHOLE WITHOUT THE WRITTEN PERMISSION OF HAVIS IS PROHIBITED.

D		09/06/18	JEB		
REV.	DESCRIPTION	DATE	BY	CHK'D	
	S. YANG	3/25/2015			
HAVIS					
TITLE CUSTOMER INSTRUCTIONS, WALL HOLSTER, PLASTIC, QUICK-RELEASE WITH ADHESIVE PADS AND MOUNTING SCREWS					
DRAWN		DATE		FINISH	
S. YANG		3/25/2015		N/A	
MATERIAL SEE B.O.M.					
FINISH N/A					
SIZE		DWG. NO.		REV.	
C		367-3282		D	
SHEET 1 OF 2					