

# INSTALLATION INSTRUCTIONS

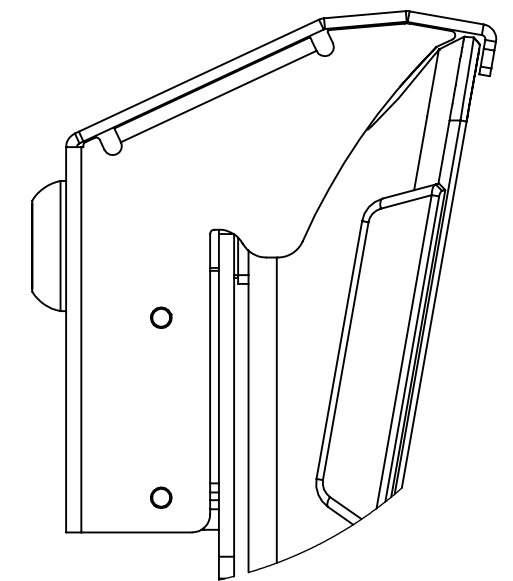
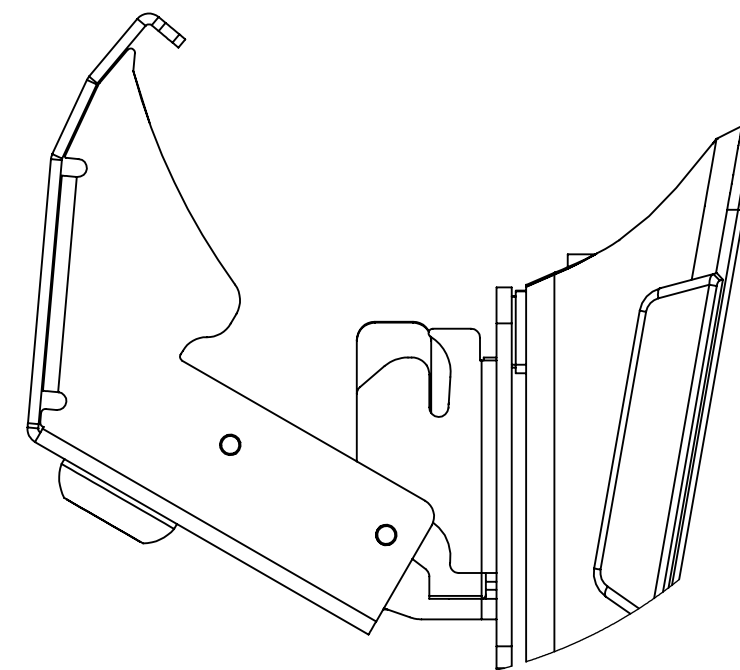
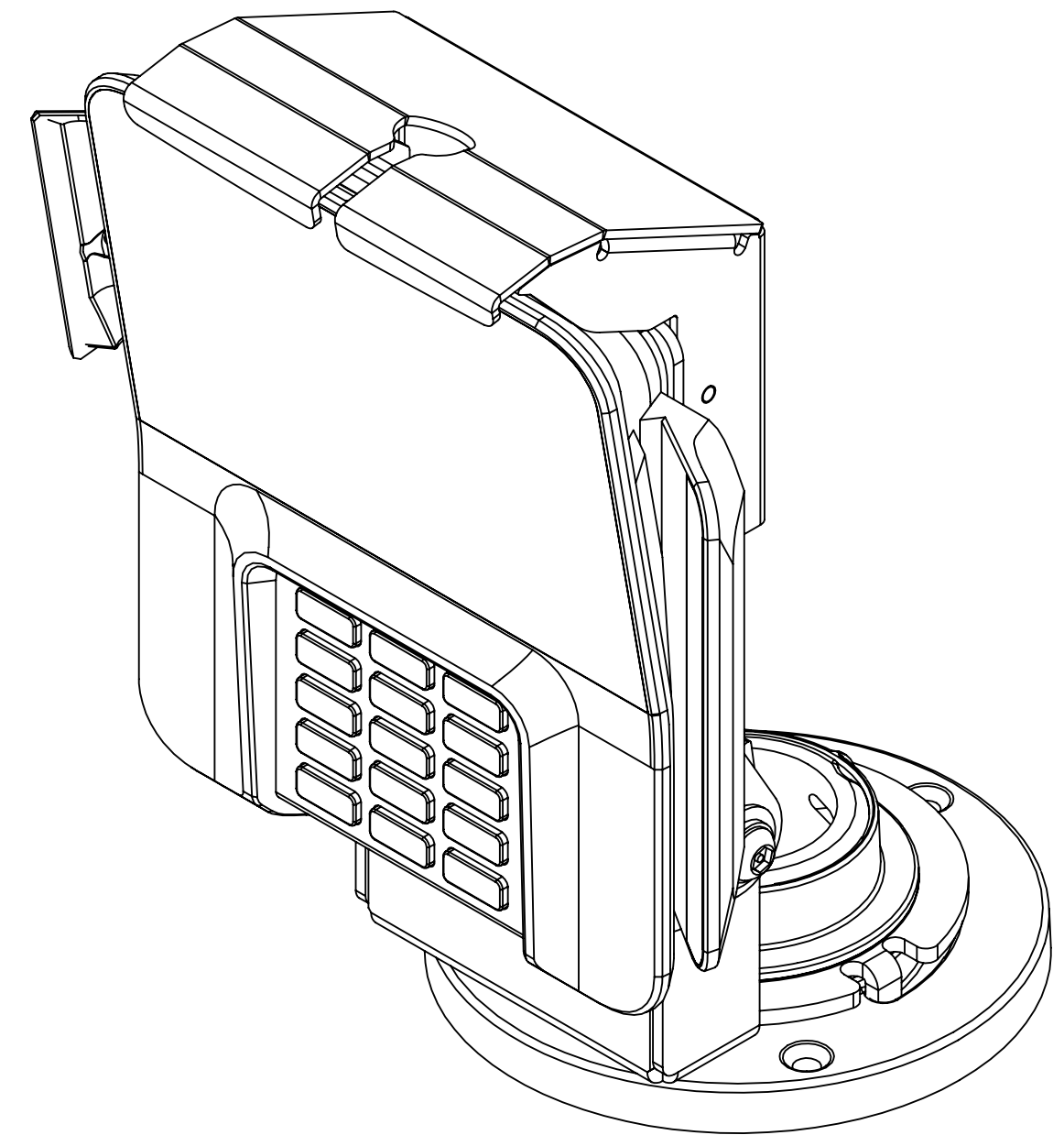
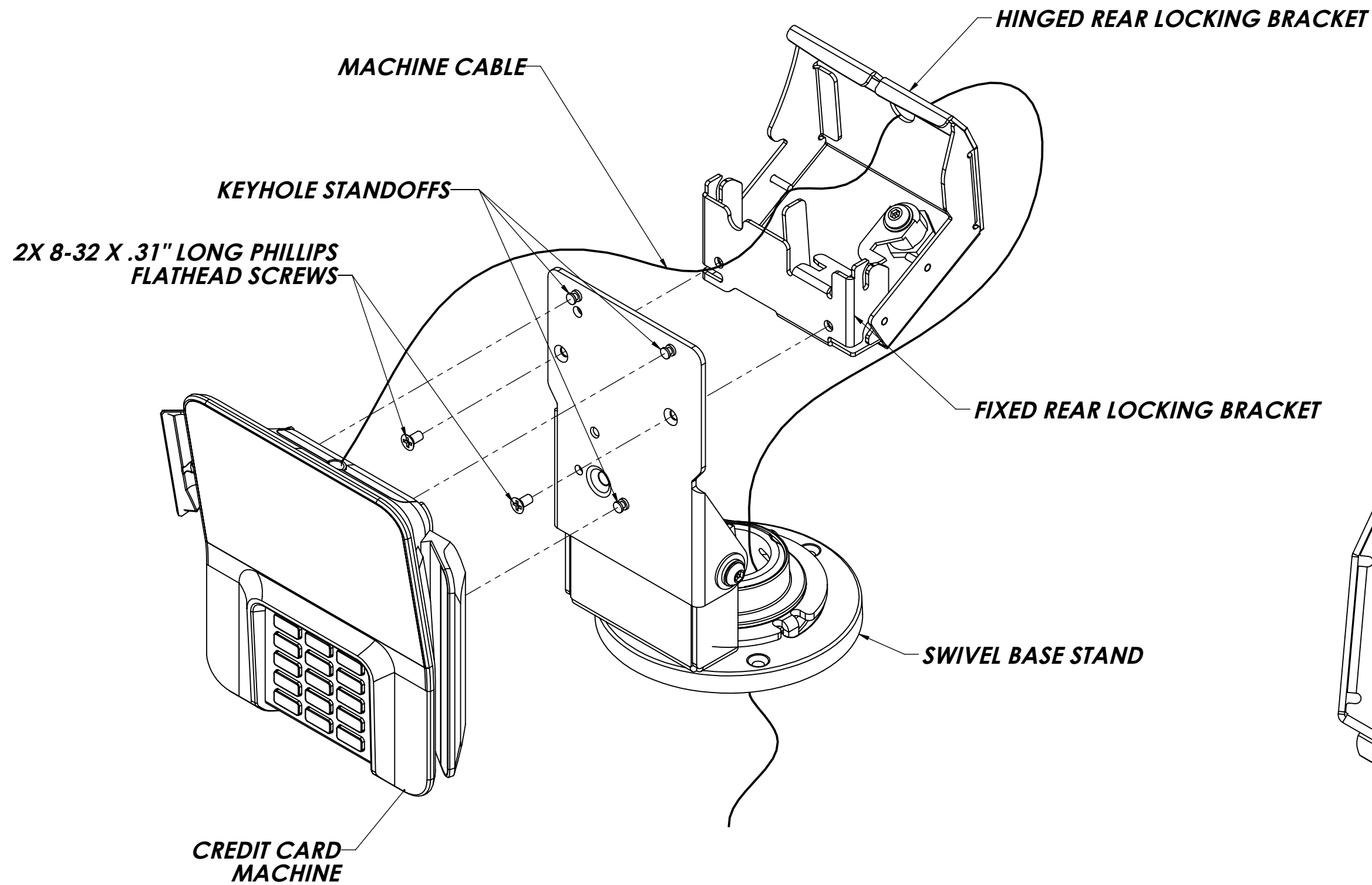

(UNLOCKED)

(LOCKED)

**DETAIL B**

**TOOL LIST:**

- #2 PHILLIPS SCREW OR DRILL DRIVER

**ASSEMBLY STEPS:**

- REMOVE **CREDIT CARD MACHINE** FROM **EXISTING CENTER HOLE SWIVEL STAND** BY REMOVING **EXISTING MACHINE THUMB SCREW** AND LIFTING OFF **3X KEYHOLE STANDOFFS** AS SHOWN.
- ATTACH **FIXED REAR LOCKING BRACKET** BY USING **2X #8-32 X .31\"/>**

**NOTE:** WHEN INSTALLING THE **FIXED REAR LOCKING BRACKET** ON A **MX915 / MX925 STAND** USE THE **2X #8-32 X .31\"/>**

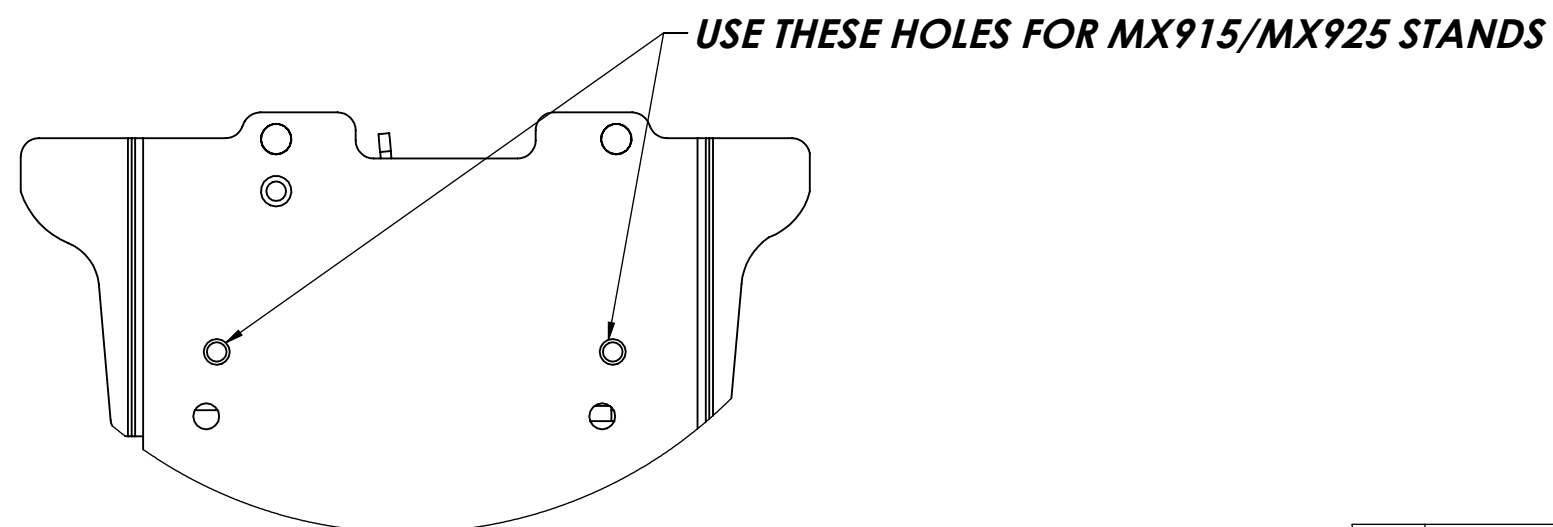

**DETAIL A**  
**MX915/MX925 STANDS**

THE INFORMATION CONTAINED IN THIS DRAWING IS THE SOLE PROPERTY OF HAVIS AND REPRODUCTION IN PART OR IN WHOLE WITHOUT THE WRITTEN PERMISSION OF HAVIS IS PROHIBITED.

REV.	DESCRIPTION	DATE	BY	CHK'D
C		10/12/20	JVT	SY
<small>DIMS AND TOLERANCES PER ASME Y14.5-1994 UNLESS OTHERWISE SPECIFIED DIMENSIONS ARE IN INCHES TOLERANCES ARE:</small>				
DRAWN T. STRAND				
DATE 9/26/2017				
CHECKED				
DATE				
FRACTIONAL ± 1/32		<b>TITLE</b> CUSTOMER INSTRUCTIONS, REAR LOCKING, ADD-ON KIT, VERIFONE M400		
2 PLC. DEC. ± .03				
3 PLC. DEC. ± .010				
ANGULAR ± 0°30'		<b>SIZE</b> C		<b>DWG. NO.</b> 367-4617
FINISH -		<b>REV.</b> C		<b>SHEET 1 OF 1</b>