

INSTALLATION INSTRUCTIONS

SHEET 1 - SCREW ATTACHMENT OPTION

(SEE SHEET 2 FOR ADHESIVE PAD OPTION)

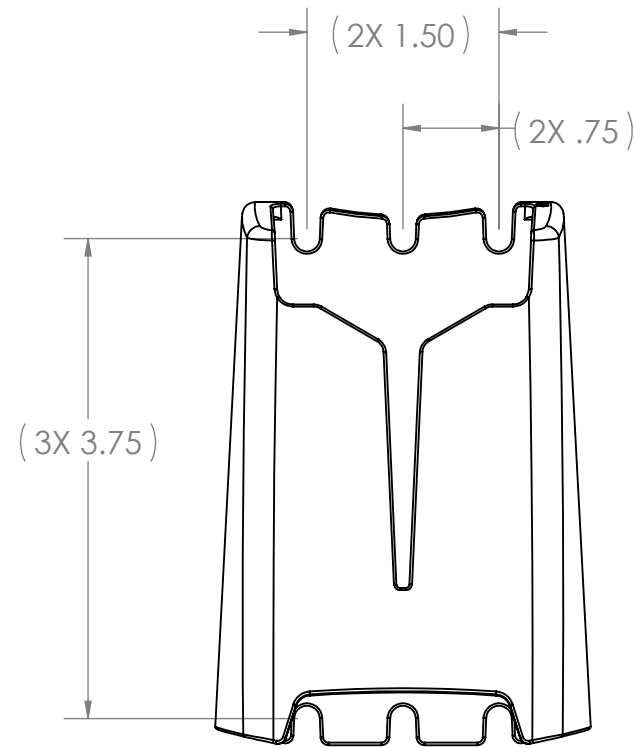

DIMENSIONING PATTERN

2X M3 X 6MM LONG PHILLIPS SCREWS

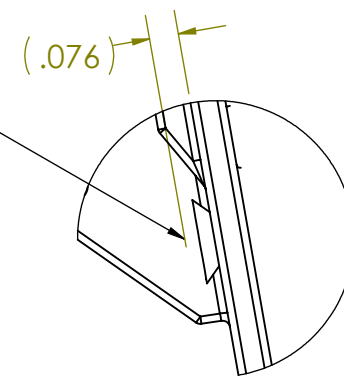

DETAIL A

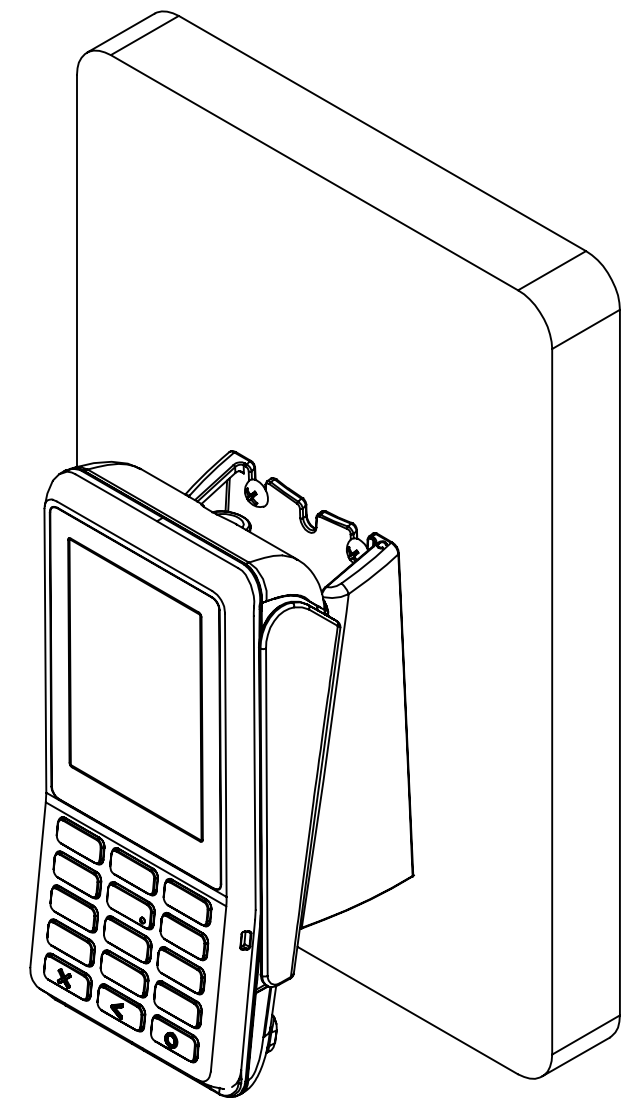
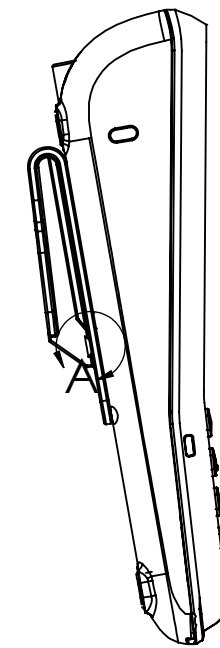

2X M3 X 6MM LONG PHILLIPS SCREWS

CREDIT CARD MACHINE
(VERIFONE P200 /400)

CLIP

WALL SECTION

4X #8 X .63" LONG
PHILLIPS SCREWS

HOLSTER

TOOLS LIST:

- #1 PHILLIPS SCREW DRIVER

ASSEMBLY STEPS:

- USING THE **HOLSTER** AS A TEMPLATE, MARK AND DRILL .09" DIAMETER HOLES INTO **WALL SECTION**. SEE: **DIMENSIONING PATTERN**.
- ATTACH **HOLSTER** TO **WALL SECTION** WITH **4X #8 X .63" LONG PHILLIPS SCREWS** AS SHOWN.
- ATTACH **CLIP** TO **CREDIT CARD MACHINE** WITH **2X M3 X 6MM LONG PHILLIPS SCREWS** AS SHOWN. **MAKE SURE TO TIGHTEN BOTH SCREWS FULLY**. SEE: **DETAIL A**
- SLIDE **CLIP** INTO **HOLSTER** AS SHOWN.

DIMS. AND TOLERANCES PER ASME Y14.5 - 1994 UNLESS OTHERWISE SPECIFIED DIMENSIONS ARE IN INCHES TOLERANCES ARE:		REV. A	DATE 9/11/2018	DESCRIPTION	DATE 9/11/18	JEB BY	JVT CHK'D
FRACTIONAL ± 1/32	2 PLC. DEC. ± .03	DRAWN J. BROWN		 TITLE CUSTOMER INSTRUCTIONS, WALL HOLSTER, PLASTIC, QUICK-RELEASE WITH ADHESIVE PADS FOR VERIFONE P200/ P400			
3 PLC. DEC. ± .010	ANGULAR ± 0°30'	DATE 9/11/2018					
DO NOT SCALE DRAWING		CHECKED					
MATERIAL N/A		DATE					
FINISH N/A		SIZE C	DWG. NO. 367-4874	REV. A	SHEET 1 OF 1		

THE INFORMATION CONTAINED IN THIS DRAWING IS THE SOLE PROPERTY OF HAVIS AND REPRODUCTION IN PART OR IN WHOLE WITHOUT THE WRITTEN PERMISSION OF HAVIS IS PROHIBITED.

INSTALLATION INSTRUCTIONS

SHEET 2 - ADHESIVE PAD OPTION

(SEE SHEET 1 FOR SCREW ATTACHMENT OPTION)

CREDIT CARD MACHINE

CLIP

WALL SECTION

HOLSTER

GLUE PAD

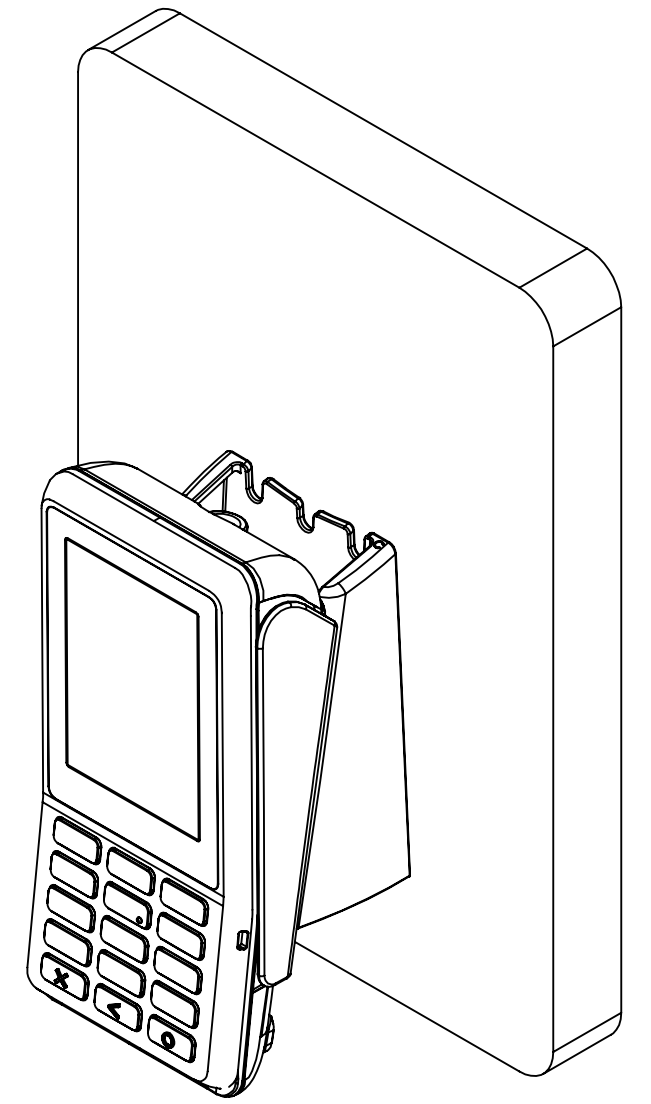

ASSEMBLY STEPS:

1. REMOVE PAPER BACKING FROM **GLUE PAD** AND ADHERE TO **HOLSTER** AS SHOWN. PRESS FIRMLY TO ENSURE A GOOD BOND. **NOTE:** BE SURE TO CLEAN MOUNTING SURFACE WITH ISOPROPYL ALCOHOL AND ALLOW TO DRY BEFORE ADHERING.
2. REMOVE PAPER BACKING FROM **GLUE PAD** ON **HOLSTER** ADHERE TO **WALL SECTION** AS SHOWN. PRESS FIRMLY TO ENSURE A GOOD BOND. **NOTE:** BE SURE TO CLEAN MOUNTING SURFACE WITH ISOPROPYL ALCOHOL AND ALLOW TO DRY BEFORE ADHERING.
3. SLIDE **CLIP** INTO **HOLSTER** AS SHOWN.
(SEE SHEET 1 FOR CLIP INSTALLATION TO VERIFONE P200/400)

	A		9/11/18	JEB	JVT
REV.		DESCRIPTION	DATE	BY	CHK'D
DRAWN J. BROWN					
DATE 9/11/2018					
CHECKED		TITLE			
DATE		CUSTOMER INSTRUCTIONS, WALL HOLSTER, PLASTIC, QUICK-RELEASE WITH ADHESIVE PADS AND MOUNTING SCREWS			
FRACTIONAL ± 1/32		MATERIAL N/A			
2 PLC. DEC. ± .03		FINISH N/A			
3 PLC. DEC. ± .010		SIZE C			
ANGULAR ± 0°30'		DWG. NO. 367-4874			
		REV. A			
		SHEET 2 OF 2			

THE INFORMATION CONTAINED IN THIS DRAWING IS THE SOLE PROPERTY OF HAVIS AND REPRODUCTION IN PART OR IN WHOLE WITHOUT THE WRITTEN PERMISSION OF HAVIS IS PROHIBITED.