

INSTALLATION INSTRUCTIONS

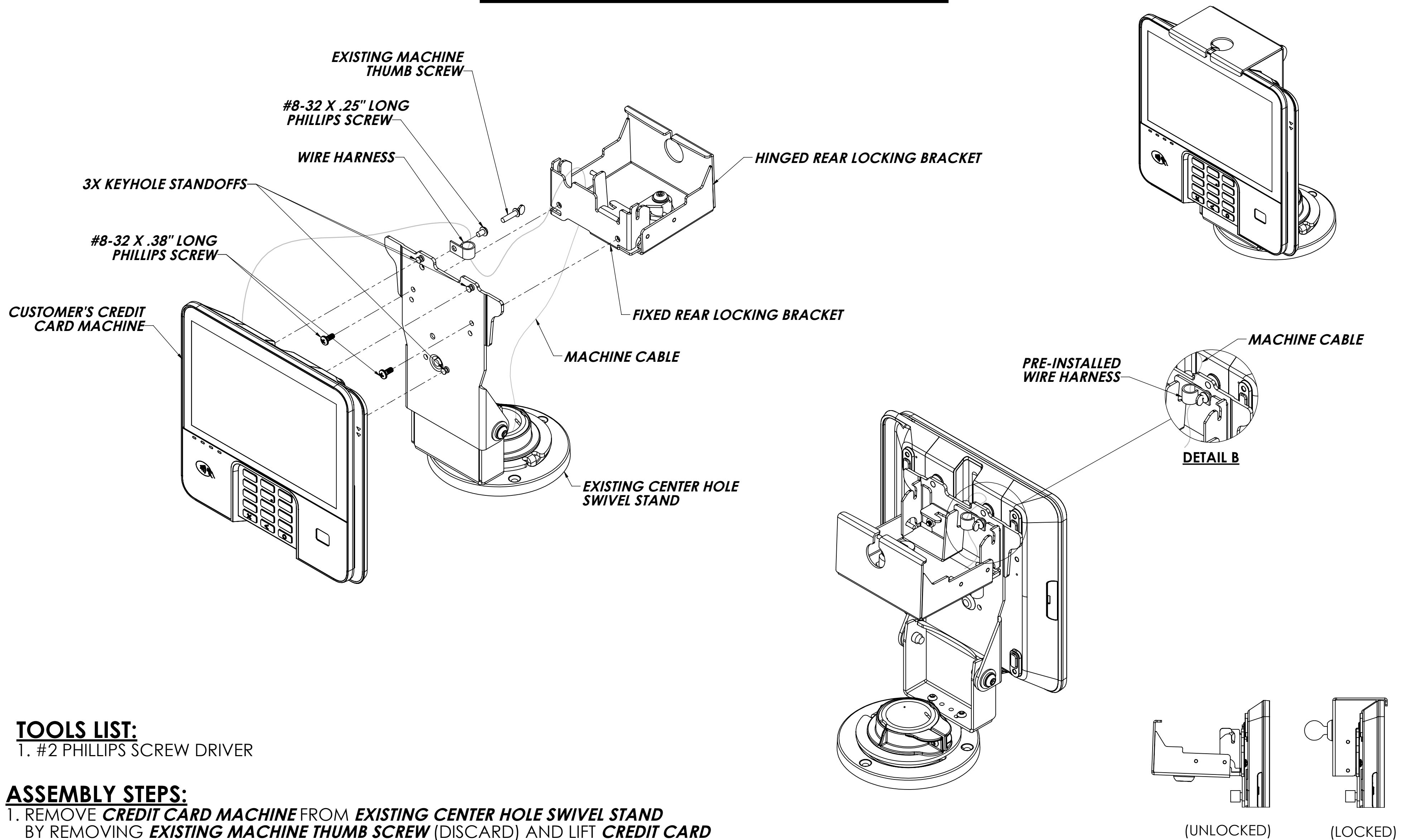

TOOLS LIST:

- #2 PHILLIPS SCREW DRIVER

ASSEMBLY STEPS:

- REMOVE **CREDIT CARD MACHINE** FROM **EXISTING CENTER HOLE SWIVEL STAND** BY REMOVING **EXISTING MACHINE THUMB SCREW** (DISCARD) AND LIFT **CREDIT CARD MACHINE** OFF OF **KEYHOLE STANDOFFS** AS SHOWN.
- ATTACH **WIRE HARNESS** USING PROVIDED **#8-32 X .25\"**
- ATTACH **FIXED REAR LOCKING BRACKET** TO **EXISTING CENTER HOLE SWIVEL STAND** BY USING **2X #8-32 X .38\"**
- REINSTALL **CREDIT CARD MACHINE** ONTO **EXISTING CENTER HOLE SWIVEL STAND** BY SLIDING IT BACK ONTO **KEYHOLE STANDOFFS**.
- FEED **MACHINE CABLE** THROUGH **CABLE CLIP** AND **FIXED REAR LOCKING BRACKET** AS SHOWN IN **DETAIL B**.
- MOVE **HINGED REAR LOCKING BRACKET** INTO PLACE AND LOCK AS SHOWN IN **DETAIL A**.

THE INFORMATION CONTAINED IN THE DRAWING IS THE SOLE PROPERTY OF HAVIS, INC. AND REPRODUCTION IN PART OR IN WHOLE WITHOUT THE WRITTEN PERMISSION OF HAVIS, INC. IS PROHIBITED.

DIMS. AND TOLERANCES PER ASME Y14.5 - 1994
UNLESS OTHERWISE SPECIFIED DIMENSIONS ARE IN INCHES TOLERANCES ARE:
FRACTIONAL ± 1/32
2 PLC. DEC. ± .03
3 PLC. DEC. ± .010
ANGULAR ± 0°30'

REV.	DESCRIPTION	DATE	BY	TAS	CHK'D
B		09/22/21	TAS	TAS	
1					
2					
3					
4					
5					
6					
7					
8					

DRAWN T. STRAND		DATE 4/8/2019		CHECKED	
DATE		DO NOT SCALE DRAWING		MATERIAL	
FINISH		SIZE C		DWG. NO. 367-5123	
TITLE		HAVIS		Havis, Inc. 14451 Ewing Ave. Burnsville, MN 55306	
TITLE		CUSTOMER INSTRUCTIONS, LOW CONTOUR 8°-90°, WITH REAR LOCKING PLATE, CENTER HOLE SWIVEL STAND, ANTI SKIMMING FEATURE, EMV CARD CLEARANCE, VERIFONE M440		REV. B	
SIZE C		DWG. NO. 367-5123		SHEET 1 OF 1	