

TOOLS LIST:

- 1. 3MM HEX WRENCH OR BIT WITH DRIVER
- 2. #1 PHILLIPS SCREW DRIVER

# DISPLAY & PRINTER INSTALL (SOME PARTS HIDDEN FOR CLARITY)

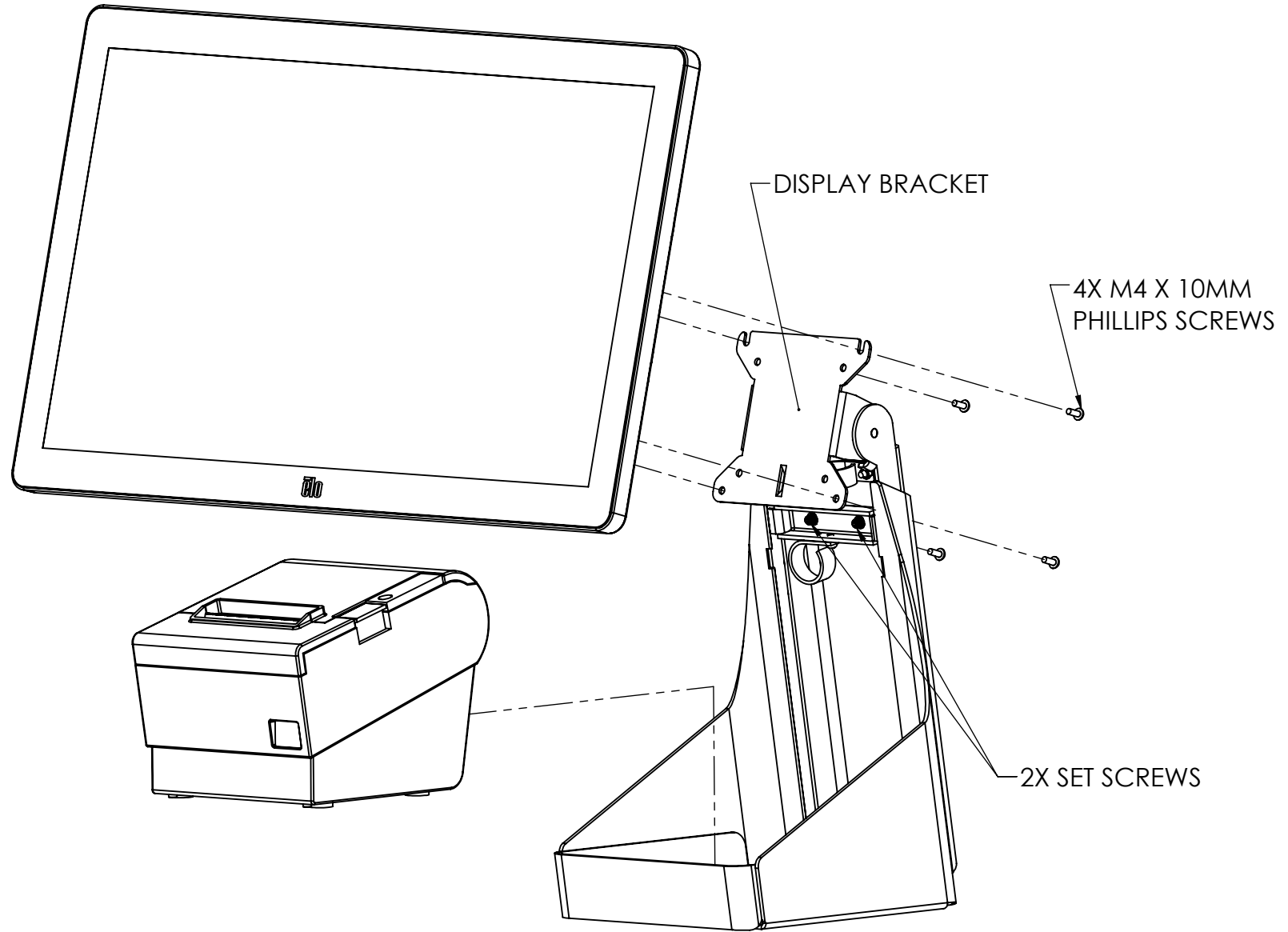
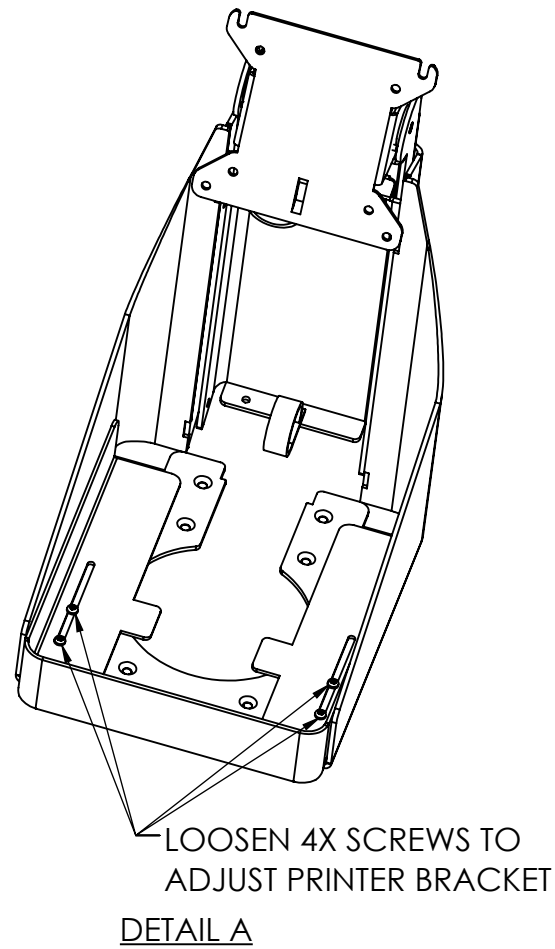

ASSEMBLY STEPS:

- 1. LOOSEN 2X SET SCREWS.
- 2. HOLD DISPLAY ATTACHMENT BRACKET AT DESIRED HEIGHT.
- 3. TIGHTEN 2X SET SCREWS.
- 4. ATTACH DISPLAY WITH 4X M4 X 10MM LONG PHILLIPS SCREWS.
- 5. PLACE PRINTER INTO SC-1000-CF UNIT. 4X SCREWS CAN BE LOOSENED TO ADJUST PRINTER BRACKET (SEE DETAIL A).  
**(OPTIONAL)** DUAL LOCK (2 STRIPS INCLUDED) CAN BE USED UNDER THE PRINTER TO HOLD IT IN PLACE IF DESIRED.

DWG. NO. <b>SC-1000-PF</b>	REV. <b>C</b>	TITLE
DRAWN <b>S. YANG</b>	DATE <b>3/27/2023</b>	

SELF CHECK-OUT,  
PEDESTAL MOUNTED,  
FREE STANDING



SHEET 1 OF 1

## CUSTOMER INSTRUCTIONS